

**SECTION BR**

GI

MA

EM

LC

EC

FE

CL

MT

AT

FA

RA

**BR**

ST

RS

BT

HA

EL

IDX

**CONTENTS**

<b>PRECAUTIONS AND PREPARATION</b> .....2	ABS Hydraulic Circuit .....37
Supplemental Restraint System (SRS)	System Components.....38
“AIR BAG” .....2	System Description .....38
Precautions for Brake System .....2	Actuator .....39
Commercial Service Tools .....2	ABS actuator operation.....39
<b>NOISE, VIBRATION AND HARSHNESS (NVH)</b>	Removal and Installation .....40
<b>TROUBLESHOOTING</b> .....3	<b>TROUBLE DIAGNOSES</b> .....44
NVH Troubleshooting Chart.....3	How to Perform Trouble Diagnoses for Quick
<b>CHECK AND ADJUSTMENT</b> .....4	and Accurate Repair .....44
Checking Brake Fluid Level.....4	Preliminary Check.....45
Checking Brake Line.....4	Component Parts and Harness Connector
Changing Brake Fluid .....4	Location.....46
<b>AIR BLEEDING</b> .....5	Schematic .....47
Bleeding Procedure .....5	Wiring Diagram –ABS–.....48
<b>BRAKE HYDRAULIC LINE</b> .....6	Self-diagnosis.....52
<b>CONTROL VALVE</b> .....8	How To Read Self-Diagnostic Results
Proportioning Valve.....8	(Malfunction codes) .....53
<b>BRAKE PEDAL AND BRACKET</b> .....10	How To Erase Self-Diagnostic Results
<b>MASTER CYLINDER</b> .....12	(Malfunction codes) .....53
<b>BRAKE BOOSTER</b> .....16	CONSULT .....55
<b>VACUUM HOSE</b> .....18	CONSULT Inspection Procedure.....56
<b>FRONT DISC BRAKE</b> .....19	Self-Diagnostic Results Mode .....57
Components.....20	Data Monitor Mode.....60
Brake Burnishing Procedure.....23	Active Test Mode .....60
<b>REAR DRUM BRAKE</b> .....24	Ground Circuit Check .....61
Components.....24	<b>TROUBLE DIAGNOSES FOR</b>
<b>REAR DISC BRAKE</b> .....27	<b>SELF-DIAGNOSTIC ITEM</b> .....62
Components.....29	<b>TROUBLE DIAGNOSES FOR SYMPTOM</b> .....73
<b>PARKING BRAKE CONTROL</b> .....35	<b>SERVICE DATA AND SPECIFICATIONS (SDS)</b> .....81
<b>ANTI-LOCK BRAKE SYSTEM</b> .....37	General Specifications.....81
Purpose.....37	Inspection and Adjustment.....82
Operation .....37	

**When you read wiring diagrams:**

- Read GI section, “HOW TO READ WIRING DIAGRAMS”.
- See EL section, “POWER SUPPLY ROUTING” for power distribution circuit.

**When you perform trouble diagnoses, read GI section, “HOW TO FOLLOW FLOW CHART IN TROUBLE DIAGNOSES” and “HOW TO PERFORM EFFICIENT DIAGNOSIS FOR AN ELECTRICAL INCIDENT”.**

## PRECAUTIONS AND PREPARATION

### Supplemental Restraint System (SRS) "AIR BAG"

The Supplemental Restraint System "AIR BAG", used along with a seat belt, helps to reduce the risk or severity of injury to the driver and front passenger in a frontal collision. The Supplemental Restraint System consists of air bag modules (located in the center of the steering wheel and on the instrument panel on the passenger side), a diagnosis sensor unit, warning lamp, wiring harness and spiral cable. Information necessary to service the system safely is included in the **RS section** of this Service Manual.

**WARNING:**

- To avoid rendering the SRS inoperative, which could increase the risk of personal injury or death in the event of a collision which would result in air bag inflation, all maintenance should be performed by an authorized NISSAN dealer.
- Improper maintenance, including incorrect removal and installation of the SRS, can lead to personal injury caused by unintentional activation of the system.
- Do not use electrical test equipment on any circuit related to the SRS unless instructed to in this Service Manual. SRS wiring harnesses are covered with yellow insulation either just before the harness connectors or on the complete harness, for easy identification.

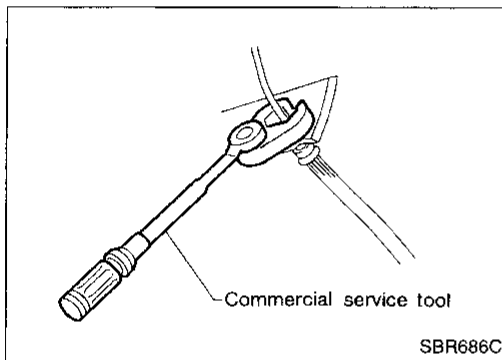

### Precautions for Brake System

- Use brake fluid DOT 3.
- Never reuse drained brake fluid.
- Be careful not to splash brake fluid on painted areas; it may cause paint damage. If brake fluid is splashed on painted areas, wash it away with water immediately.
- To clean master cylinder parts, disc brake caliper parts or wheel cylinder parts, use clean brake fluid.
- Never use mineral oils such as gasoline or kerosene. They will ruin rubber parts of the hydraulic system.
- Use flare nut wrench when removing and installing brake tubes.
- Always torque brake lines when installing.

**WARNING:**

- Clean brakes with a vacuum dust collector to minimize the hazard of airborne materials.

### Commercial Service Tools

Tool name	Description	
<ul style="list-style-type: none"> <li>① Flare nut crowfoot</li> <li>② Torque wrench</li> </ul>	<p style="text-align: center;">NT360</p>	<p>Removing and installing brake lines</p> <p style="text-align: center;">a: 10 mm (0.39 in)</p>
<p>Brake fluid pressure gauge</p>	<p style="text-align: center;">NT151</p>	<p>Measuring brake fluid pressure</p>

# NOISE, VIBRATION AND HARSHNESS (NVH) TROUBLESHOOTING

## NVH Troubleshooting Chart

Use the table below to help you find the cause of the symptom. If necessary, repair or replace these parts.

Reference page			BR-19, 24, 27	BR-19, 26, 27	BR-24	BR-20, 29	—	—	BR-22, 32	—	—	—	BR-22, 32	BR-26	NVH in FA section	NVH in FA section	NVH in FA, RA section	NVH in FA section	NVH in ST section
Possible cause and SUSPECTED PARTS			Linings or pads - damaged	Linings or pads - uneven wear	Return springs damaged	Shims damaged	Rotor or drum imbalance	Rotor or drum damage	Rotor runout	Rotor or drum deformation	Rotor or drum deflection	Rotor or drum rust	Rotor thickness variation	Drum out of round	DRIVESHAFT	AXLE AND SUSPENSION	TIRES	ROAD WHEEL	STEERING
Symptom	BRAKE	Noise	X	X	X	X													
		Shake					X								X	X	X	X	X
		Shimmy, Judder					X	X	X	X	X	X	X	X		X	X	X	X

X: Applicable

GI  
 MA  
 EM  
 LC  
 EC  
 FE  
 CL  
 MT  
 AT  
 FA  
 RA  
**BR**  
 ST  
 RS  
 BT  
 HA  
 EL  
 IDX

## CHECK AND ADJUSTMENT

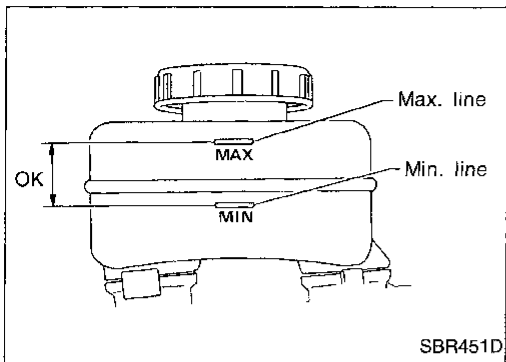

### Checking Brake Fluid Level

- Check fluid level in reservoir tank. It should be between Max. and Min. lines on reservoir tank.
- If fluid level is extremely low, check brake system for leaks.
- If the brake warning lamp comes on, check brake fluid level switch and parking brake switch.

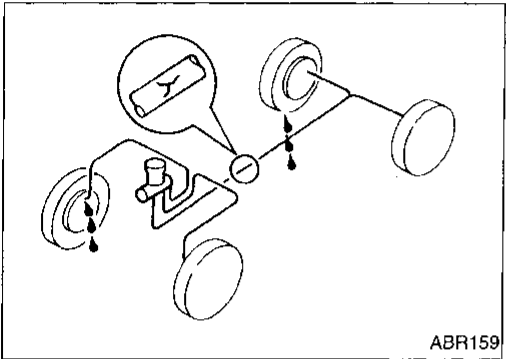

### Checking Brake Line

#### CAUTION:

If leakage occurs around joints, retighten or, if necessary, replace damaged parts.

1. Check brake lines (tubes and hoses) for cracks, deterioration or other damage. Replace any damaged parts.
2. Check for oil leakage by fully depressing brake pedal while engine is running.

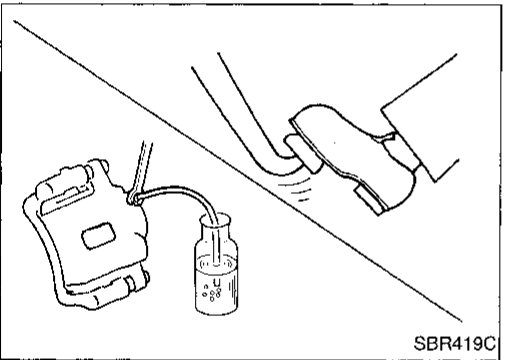

### Changing Brake Fluid

#### CAUTION:

- Refill with new brake fluid DOT 3.
- Always keep fluid level higher than minimum line on reservoir tank.
- Never reuse drained brake fluid.
- Be careful not to splash brake fluid on painted areas; it may cause paint damage. If brake fluid is splashed on painted areas, wash it away with water immediately.

1. Clean inside of reservoir tank, and refill with new brake fluid.
2. Connect a vinyl tube to each air bleeder valve.
3. Drain brake fluid from each air bleeder valve by depressing brake pedal.
4. Refill until new brake fluid comes out of each air bleeder valve.

Use same procedure as in bleeding hydraulic system to refill brake fluid.

Refer to "Bleeding Procedure", BR-5.

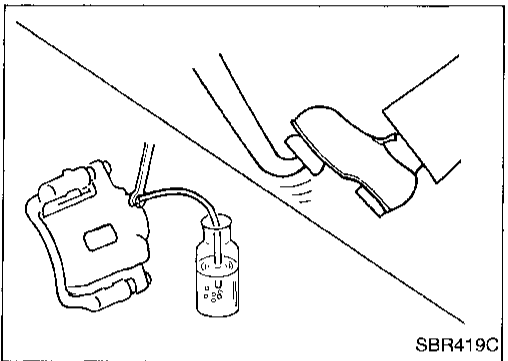
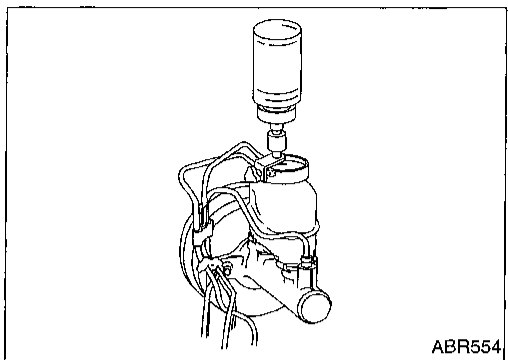

## Bleeding Procedure

### CAUTION:

- Carefully monitor brake fluid level at master cylinder during bleeding operation. GI
  - If master cylinder is suspected to have air inside, bleed air from master cylinder first. Refer to "Installation", "MASTER CYLINDER", BR-14. MA
  - Fill reservoir with new brake fluid DOT 3. Make sure it is full at all times while bleeding air out of system. EM
  - Place a container under master cylinder to avoid spillage of brake fluid. LC
  - For models with ABS, turn ignition switch OFF and disconnect ABS actuator connector or battery cable. EC
  - Bleed air in the following order:  
Right rear brake→Left front brake→Left rear brake→Right front brake. FE
  - 1. Connect a transparent vinyl tube to air bleeder valve. CL
  - 2. Fully depress brake pedal several times. MT
  - 3. With brake pedal depressed, open air bleeder valve to release air. AT
  - 4. Close air bleeder valve. FA
  - 5. Release brake pedal slowly. RA
  - 6. Repeat steps 2. through 5. until clear brake fluid comes out of air bleeder valve. BR
  - 7. Tighten air bleeder valve. ST
- ⚙️: 7 - 9 N·m (0.7 - 0.9 kg·m, 61 - 78 in·lb)

BR

ST

RS

BT

HA

EL

IDX

# BRAKE HYDRAULIC LINE

**Without anti-lock brake system**  
 (Models with dual proportioning valve built into master cylinder)  
 (built-in type)

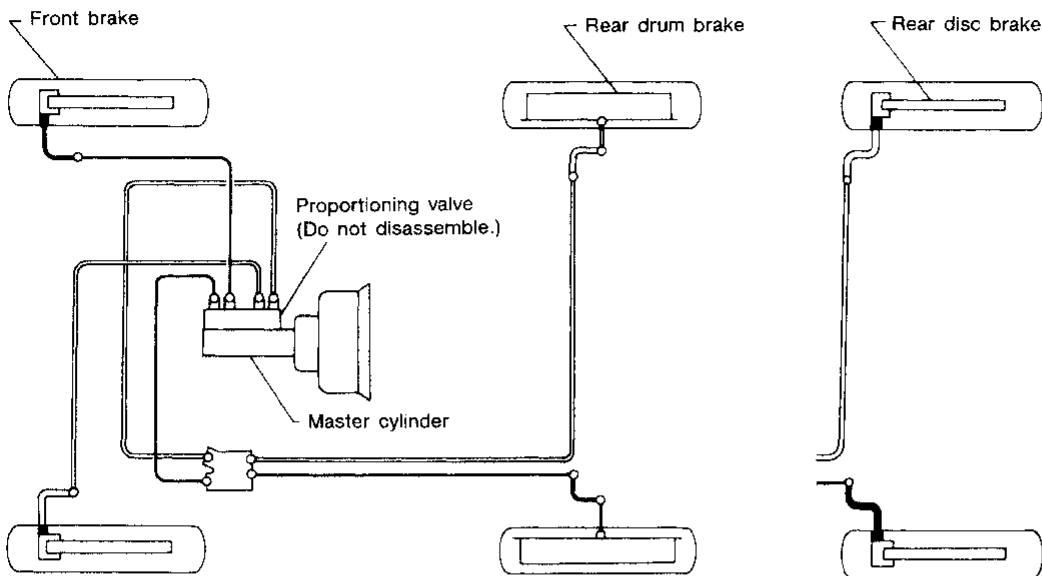

**With anti-lock brake system**

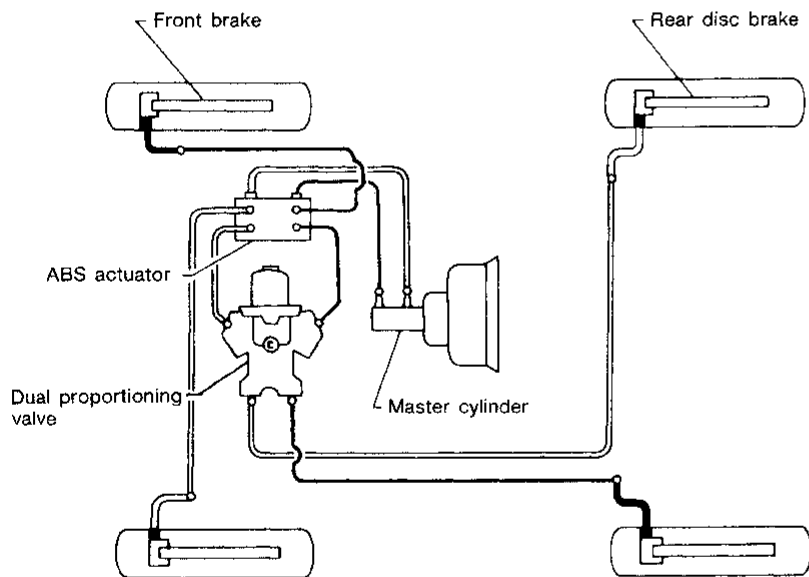

- : Primary line
- : Secondary line
- : Flare nut  
15 - 18 (1.5 - 1.8, 11 - 13)
- ⊠ : Connecting bolt  
17 - 20 (1.7 - 2.0, 12 - 14)
- ⊞ : N·m (kg·m, ft·lb)

BBR002

# BRAKE HYDRAULIC LINE

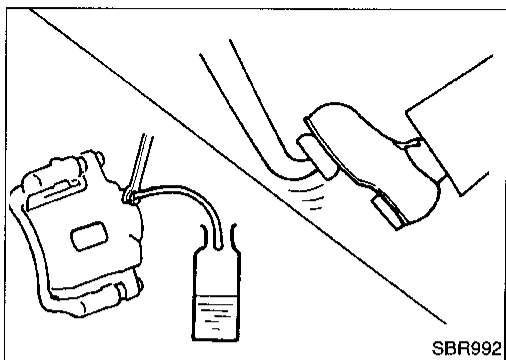

## REMOVAL

### CAUTION:

- Be careful not to splash brake fluid on painted areas; it may cause paint damage. If brake fluid is splashed on painted areas, wash it away with water immediately. GI
  - All hoses must be free from excessive bending, twisting and pulling. MA
1. Connect a vinyl tube to air bleeder valve. EM
  2. Drain brake fluid from each air bleeder valve by depressing brake pedal. LC
  3. Remove flare nut securing brake tube to hose, then withdraw lock spring. EC
  4. Cover openings to prevent entrance of dirt when disconnecting hydraulic line.

## INSPECTION

Check brake lines (tubes and hoses) for cracks, deterioration or other damage. Replace any damaged parts. FE

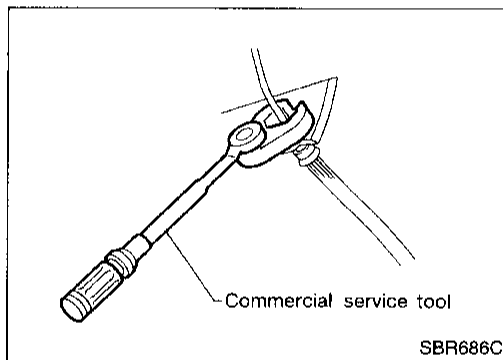

## INSTALLATION

### CAUTION:

- Refill with new brake fluid DOT 3.
  - Never reuse drained brake fluid.
1. Tighten all flare nuts and connecting bolts.
    - Flare nut:  
☞: 15 - 18 N·m (1.5 - 1.8 kg-m, 11 - 13 ft-lb)
    - Connecting bolt:  
☞: 17 - 20 N·m (1.7 - 2.0 kg-m, 12 - 14 ft-lb)
  2. Refill until new brake fluid comes out of each air bleeder valve.
  3. Bleed air. Refer to "Bleeding Procedure", BR-5.

BR

ST

RS

BT

HA

EL

IDX

## Proportioning Valve

### INSPECTION

#### CAUTION:

- Carefully monitor brake fluid level at master cylinder.
  - Use new brake fluid DOT 3.
  - Be careful not to splash brake fluid on painted areas; it may cause paint damage. If brake fluid is splashed on painted areas, wash it away with water immediately.
  - Depress pedal slowly when raising front brake pressure.
  - Check rear brake pressure 2 seconds after front brake pressure reaches specified value.
  - For models with ABS, disconnect harness connectors from ABS actuator relay box before checking.
1. Connect Tool to air bleeders of front and rear brakes on either LH or RH side.
  2. Bleed air from the Tool.
  3. Check fluid pressure by depressing brake pedal.

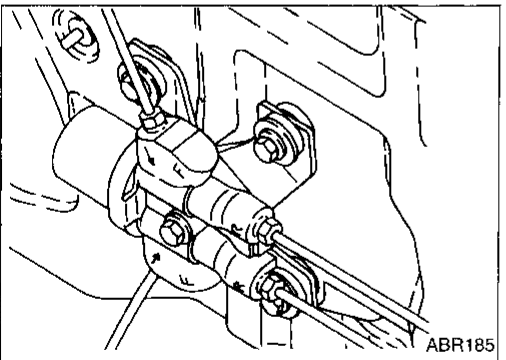
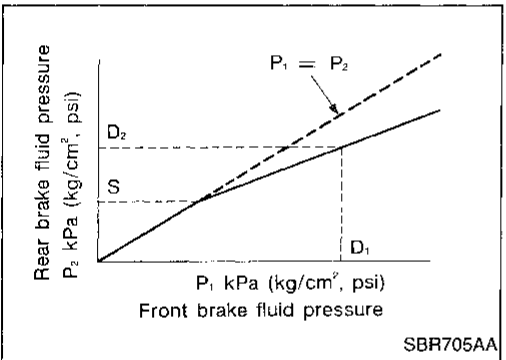
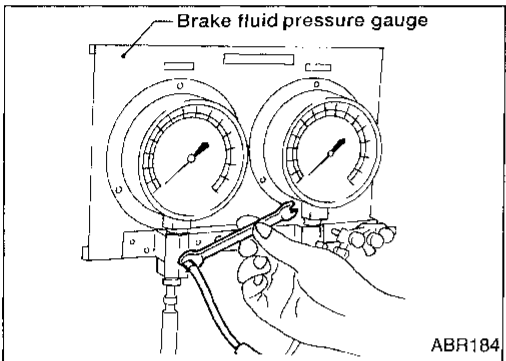
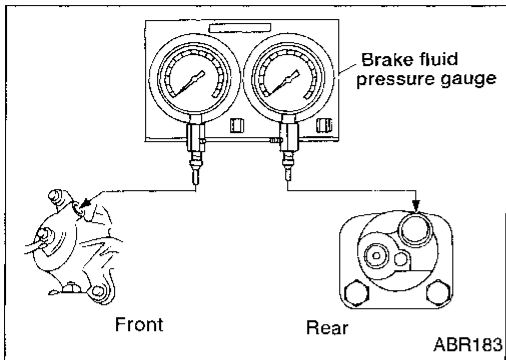

### REMOVAL (Separated type)

#### CAUTION:

- Be careful not to splash brake fluid on painted areas; it may cause paint damage. If brake fluid is splashed on painted areas, wash it away with water immediately.
  - All hoses must be free from excessive bending, twisting and pulling.
1. Connect a vinyl tube to air bleeder valve.
  2. Drain brake fluid from each air bleeder valve by depressing brake pedal.
  3. Loosen flare nut.
  4. Remove proportioning valve mounting bolt, then remove flare nut.

Applied pressure (Front brake) $D_1$	kPa (kg/cm <sup>2</sup> , psi)	7,355 (75, 1,067)
Output pressure (Rear brake) $D_2$	kPa (kg/cm <sup>2</sup> , psi)	5,100 - 5,492 (52 - 56, 739 - 796)

If output pressure is out of specifications, replace dual proportioning valve (separated type) or master cylinder assembly (built-in type).

4. Bleed air after disconnecting the Tool. Refer to "Bleeding Procedure", BR-5.



## CONTROL VALVE

### Proportioning Valve (Cont'd)

#### INSTALLATION (Separated type)

##### CAUTION:

- Refill with new brake fluid DOT 3. GI
- Never reuse drained brake fluid.
- 1. Temporarily fit flare nut to proportioning valve. MA
- 2. Tighten proportioning valve mounting bolt, then tighten flare nut.

##### Flare nut:

: 15 - 18 N·m (1.5 - 1.8 kg-m, 11 - 13 ft-lb) EM

- 3. Refill until new brake fluid comes out of each air bleeder valve. LC
- 4. Bleed air. Refer to "Bleeding Procedure", BR-5. LC

#### REMOVAL AND INSTALLATION (Built-in type)

Always replace together with master cylinder as an assembly. EC

- Refer to "MASTER CYLINDER", BR-12. FE

CL

MT

AT

FA

RA

**BR**

ST

RS

BT

HA

EL

IDX

# BRAKE PEDAL AND BRACKET

## Removal and Installation

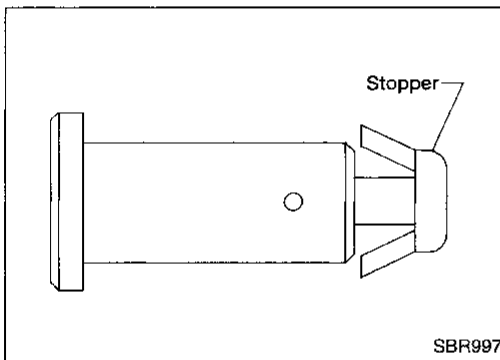
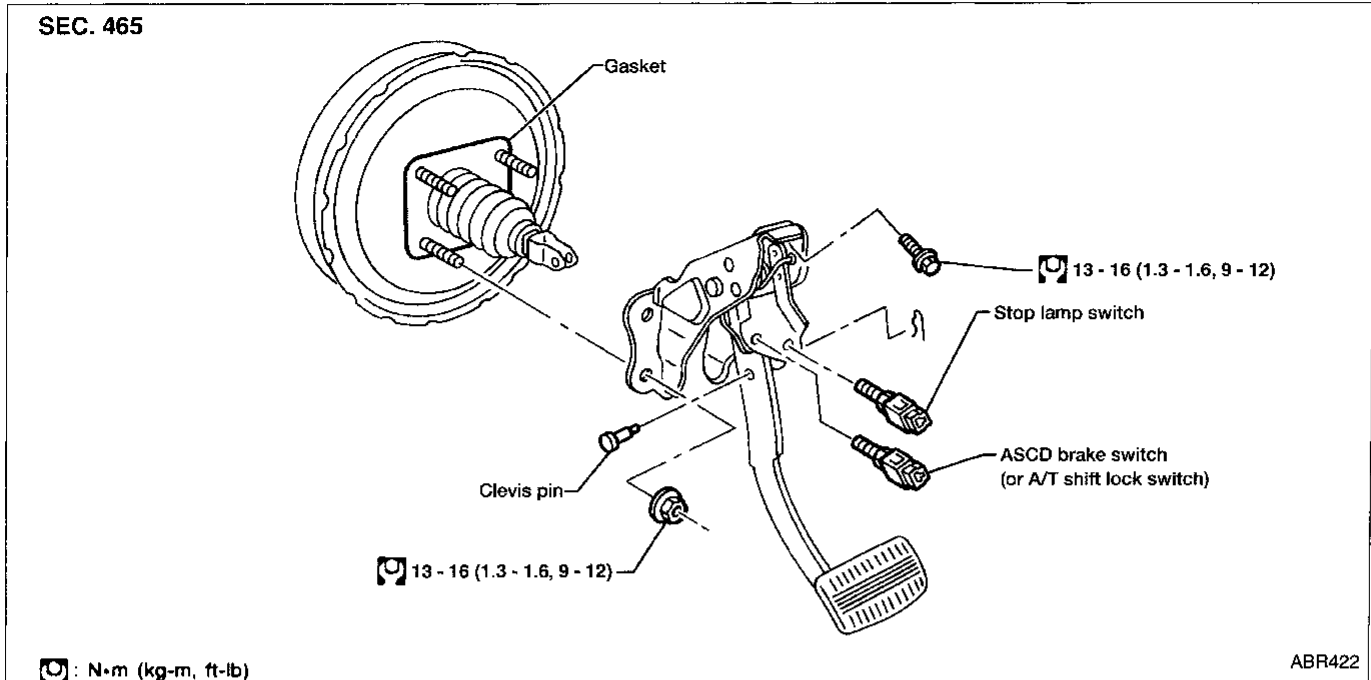

### Inspection

Check brake pedal for following items:

- Brake pedal bend
- Clevis pin deformation
- Crack of any welded portion
- Crack or deformation of clevis pin plastic stopper

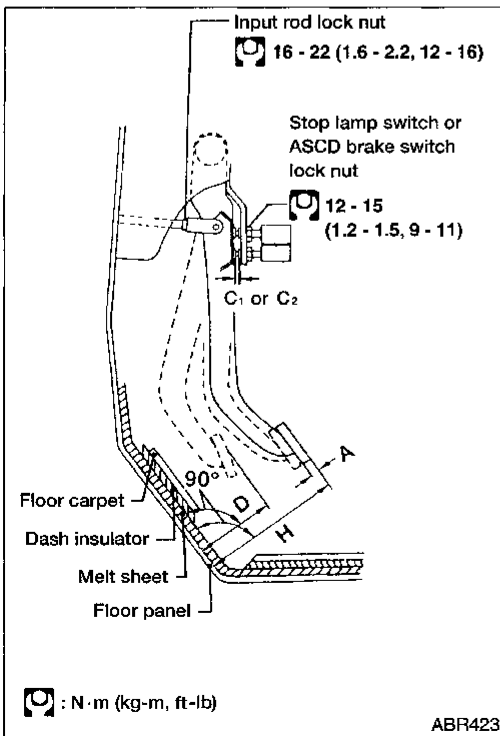

### Adjustment

Check brake pedal free height from floor panel.

**H:** Free height

Refer to SDS, BR-82.

**D:** Depressed height

Refer to SDS, BR-82.

Under force of 490 N (50 kg, 110 lb)  
with engine running

**C<sub>1</sub>, C<sub>2</sub>:** Clearance between pedal stopper and  
threaded end of stop lamp switch and ASCD  
brake switch

0.3 - 1.0 mm (0.012 - 0.039 in)

**A:** Pedal free play (at pedal pad)

1.0 - 3.0 mm (0.039 - 0.118 in)

# BRAKE PEDAL AND BRACKET

## Adjustment (Cont'd)

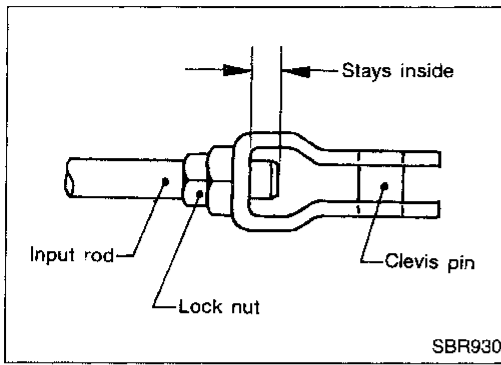

If necessary, adjust brake pedal free height.

1. Loosen lock nut and adjust pedal free height by turning brake booster input rod. Then tighten lock nut.
- **Make sure that the tip of input rod stays inside.**
2. Loosen lock nut and adjust clearance "C<sub>1</sub>" and "C<sub>2</sub>" with stop lamp switch and ASCD brake switch (or A/T shift lock switch) respectively. Then tighten lock nuts.
3. Check pedal free play.

**Make sure that stop lamps go off when pedal is released.**

4. Check brake pedal's depressed height while engine is running. If lower than specification, check for leaks, air in system, or damage to components (master cylinder, wheel cylinder, etc.). Then make necessary repairs.

GI

MA

EM

LC

EC

FE

CL

MT

AT

FA

RA

**BR**

ST

RS

BT

HA

EL

IDX

# MASTER CYLINDER

## Removal

### CAUTION:

- Be careful not to splash brake fluid on painted areas; it may cause paint damage. If brake fluid is splashed on painted areas, wash it away with water immediately.
  - In the case of brake fluid leakage from the master cylinder, disassemble the cylinder. Then check piston cups for deformation or scratches and replace necessary parts.
1. Connect a vinyl tube to air bleeder valve.
  2. Drain brake fluid from each air bleeder valve, depressing brake pedal to empty fluid from master cylinder.
  3. Remove brake line flare nuts.
  4. Remove master cylinder mounting nuts.

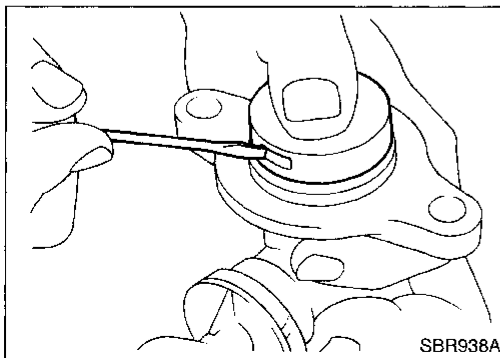
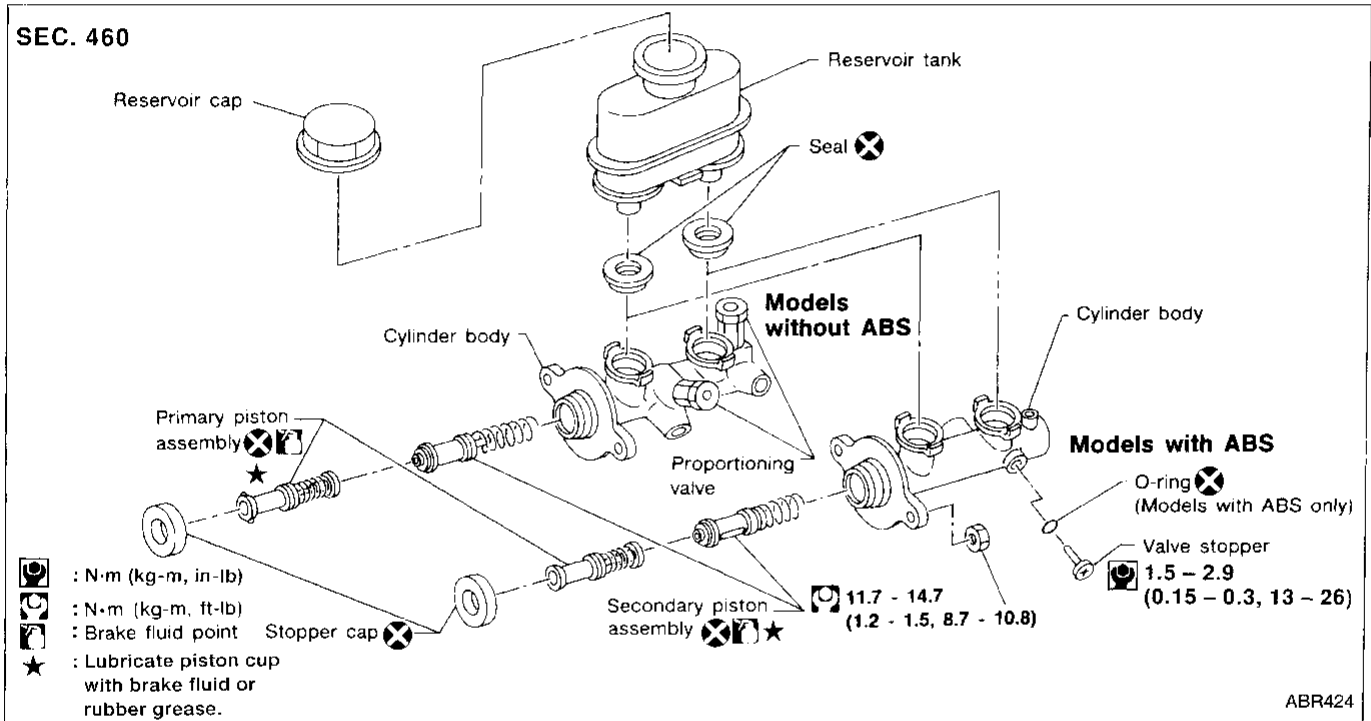

## Disassembly

1. Bend claws of stopper cap outward.

# MASTER CYLINDER

## Disassembly (Cont'd)

2. Remove valve stopper while piston is pushed into cylinder (Models with ABS only).
3. Remove piston assemblies.

**If it is difficult to remove secondary piston assembly, gradually apply compressed air through fluid outlet.**

4. Remove reservoir tank.

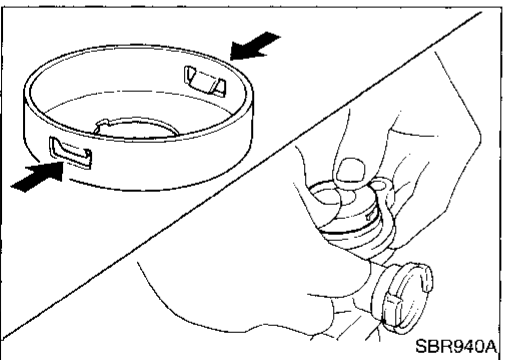
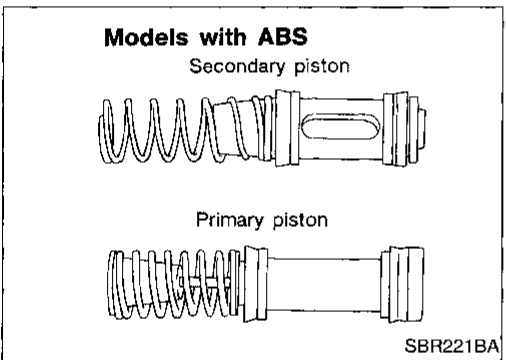
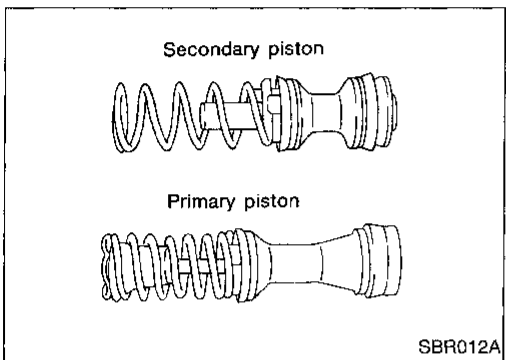
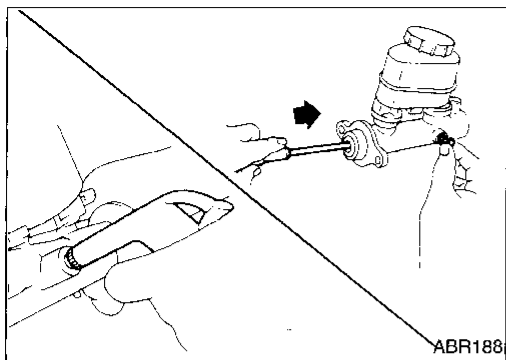

## Inspection

Check master cylinder inner wall for pin holes or scratches. Replace if damaged.

## Assembly

1. Insert secondary piston assembly. Then insert primary piston assembly.
- Pay attention to direction of piston cups in figure at left. Also, insert pistons squarely to avoid scratches on cylinder bore.
  - Pay attention to alignment of secondary piston slit with valve stopper mounting hole of cylinder body (For models with ABS only).

2. Install stopper cap.

**Before installing stopper cap, ensure that claws are bent inward.**

3. Push reservoir tank seals into cylinder body.
4. Push reservoir tank into cylinder body.

GI

MA

EM

LC

EC

FE

CL

MT

AT

FA

RA

**BR**

ST

RS

BT

HA

EL

IDX

## MASTER CYLINDER

### Assembly (Cont'd)

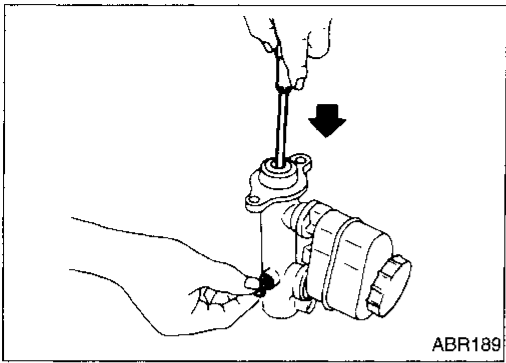

5. Install valve stopper while piston is pushed into cylinder. (Models with ABS only)

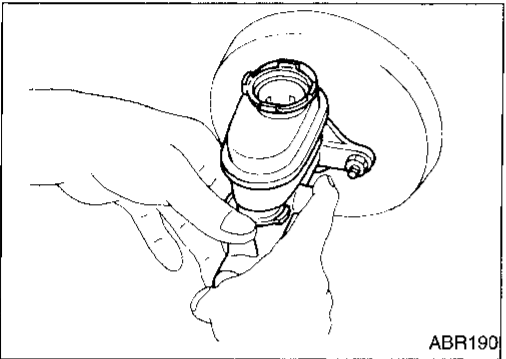

### Installation

#### CAUTION:

- Refill with new brake fluid DOT 3.
  - Never reuse drained brake fluid.
1. Place master cylinder onto brake booster and secure mounting nuts lightly.
  2. Tighten mounting nuts.  
⚙️: 11.7 - 17.6 N·m (1.2 - 1.8 kg-m, 9 - 13 ft-lb)
  3. Fill up reservoir tank with new brake fluid.
  4. Plug all ports on master cylinder with fingers to prevent air suction while releasing brake pedal.
  5. Have driver depress brake pedal slowly several times until no air comes out of master cylinder.
  6. Fit brake lines to master cylinder.
  7. Tighten flare nuts.  
⚙️: 15 - 18 N·m (1.5 - 1.8 kg-m, 11 - 13 ft-lb)
  8. Bleed air. Refer to "Bleeding Procedure", BR-5

# MASTER CYLINDER

---

## NOTES

GI

MA

EM

LC

EC

FE

CL

MT

AT

FA

RA

**BR**

ST

RS

BT

HA

EL

IDX

# BRAKE BOOSTER

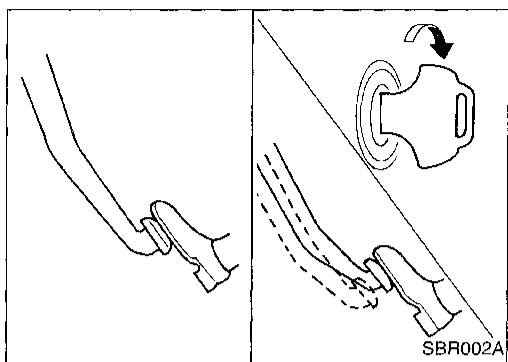

## On-vehicle Service

### OPERATING CHECK

- Depress brake pedal several times with engine off. After exhausting vacuum, make sure there is no change in pedal stroke.
- Depress brake pedal, then start engine. If pedal goes down slightly, operation is normal.

### AIRTIGHT CHECK

- Start engine, and stop it after one or two minutes. Depress brake pedal several times slowly. Booster is airtight if pedal stroke is less each time.
- Depress brake pedal while engine is running, and stop engine with pedal depressed. The pedal stroke should not change after holding pedal down for **30 seconds**.

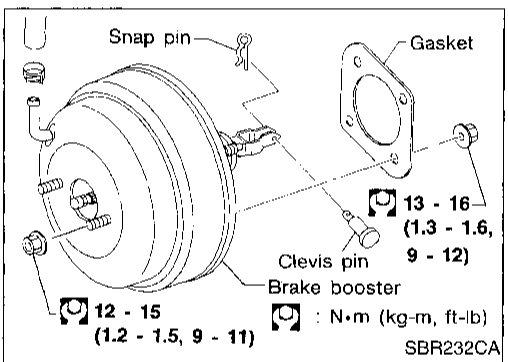
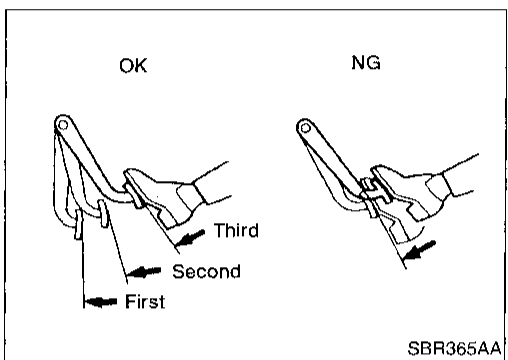

## Removal

### CAUTION:

- Be careful not to splash brake fluid on painted areas; it may cause paint damage. If brake fluid is splashed on painted areas, wash it away with water immediately.
- Be careful not to deform or bend brake tubes during removal of booster.

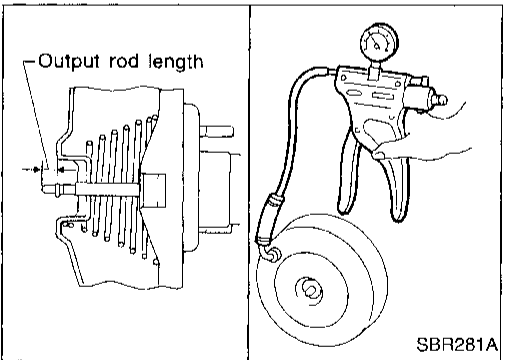

## Inspection

### OUTPUT ROD LENGTH CHECK

1. Apply vacuum of  $-66.7 \text{ kPa}$  ( $-500 \text{ mmHg}$ ,  $-19.69 \text{ inHg}$ ) to brake booster with a hand vacuum pump.
2. Check output rod length.

#### Specified length:

**M195, S205 OR C205**

**10.275 - 10.525 mm (0.4045 - 0.4144 in)**



# BRAKE BOOSTER

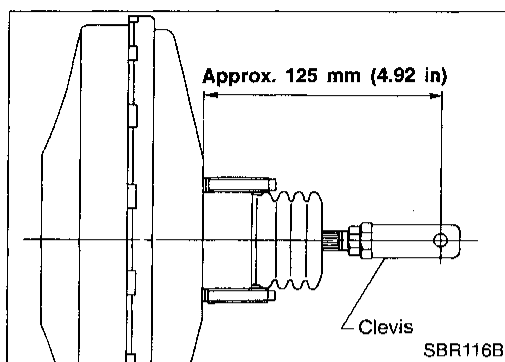

## Installation

### CAUTION:

- Be careful not to deform or bend brake tubes during installation of booster. GI
- Replace clevis pin if damaged. MA
- Refill with new brake fluid DOT 3. EM
- Never reuse drained brake fluid. EM
- Take care not to damage brake booster mounting bolt thread when installing. Due to the narrow angle of installation, the threads can be damaged by the dash panel. EM

1. Before fitting booster, temporarily adjust clevis to dimension shown. (Does not apply to models with ABS). LC
2. Fit booster, then secure mounting nuts (brake pedal bracket to brake booster) lightly. EC
3. Connect brake pedal and booster input rod with clevis pin.
4. Secure mounting nuts. FE

: 13 - 16 N·m (1.3 - 1.6 kg-m, 9 - 12 ft-lb)

5. Install master cylinder. Refer to BR-14. CL
6. Adjust brake pedal height. Refer to BR-10. CL
7. Bleed air. Refer to "Bleeding Procedure", BR-5. CL

MT

AT

FA

RA

**BR**

ST

RS

BT

HA

EL

IDX

# VACUUM HOSE

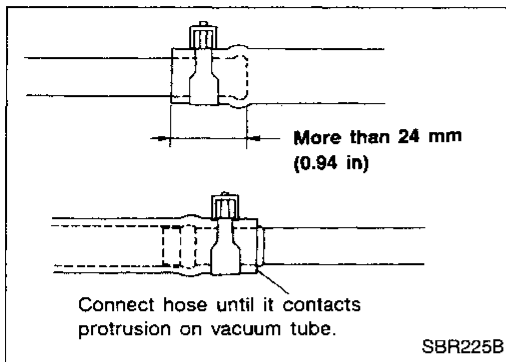

## Removal and Installation

### CAUTION:

When installing vacuum hoses, pay attention to the following points.

- Do not apply any oil or lubricants to vacuum hose and check valve.
- Insert vacuum tube into vacuum hose as shown.

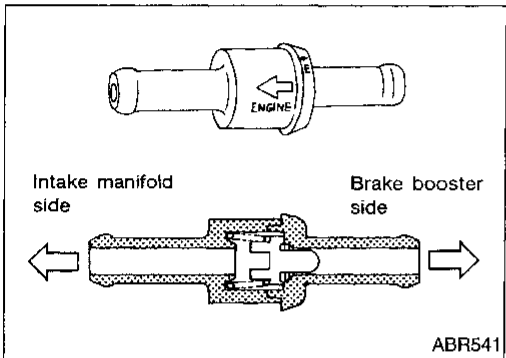

- Install check valve, paying attention to its direction.

## Inspection

### HOSES AND CONNECTORS

Check vacuum lines, connections and check valve for airtightness, improper attachment, chafing or deterioration.

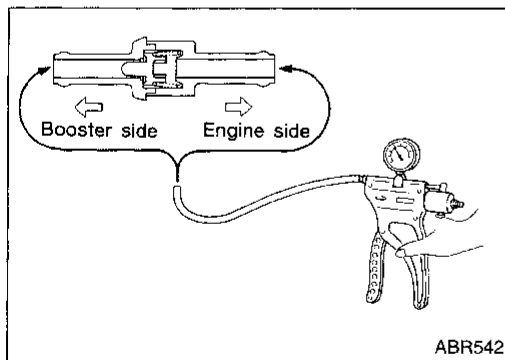

### CHECK VALVE

Check vacuum with a vacuum pump.

Connect to booster side	Vacuum should exist.
Connect to engine side	Vacuum should not exist.

## Pad Replacement

### WARNING:

Clean brake pads with a vacuum dust collector to minimize the hazard of airborne particles or other materials. GI

### CAUTION:

- When cylinder body is open, do not depress brake pedal or caliper piston will pop out. MA
- Be careful not to damage piston boot or get oil on rotor. Always replace shims when replacing pads. EM
- If shims are rusted or show peeling of the rubber coat, replace them with new shims. LC
- It is not necessary to remove connecting bolt except for disassembly or replacement of caliper assembly. In this case, suspend cylinder body with wire so as not to stretch brake hose. EC

FE

CL

MT

AT

FA

RA

BR

ST

RS

BT

HA

EL

IDX

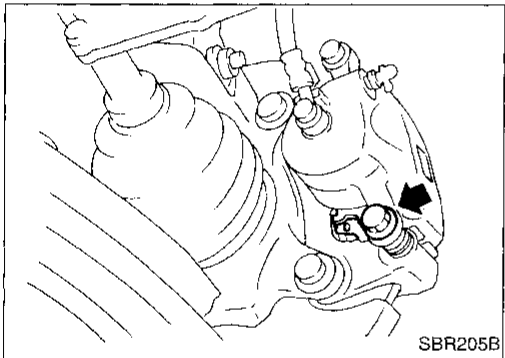

1. Remove master cylinder reservoir cap.
2. Remove lower pin bolt.

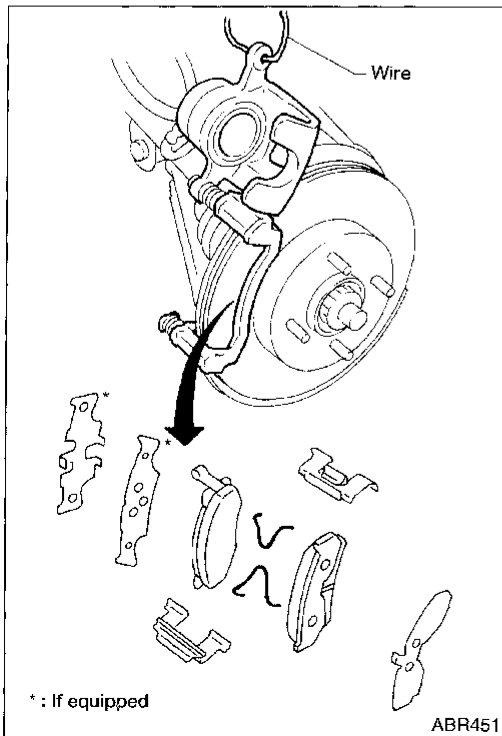

3. Open cylinder body upward. Then remove pad retainers, return spring, inner shim and cover (if equipped) and outer shim.

#### Standard pad thickness:

11 mm (0.44 in)

#### Pad wear limit:

2.0 mm (0.079 in)

Carefully monitor brake fluid level because brake fluid will return to reservoir when pushing back piston.

# FRONT DISC BRAKE

## Components

CL22VD and CL22VE  
SEC. 440

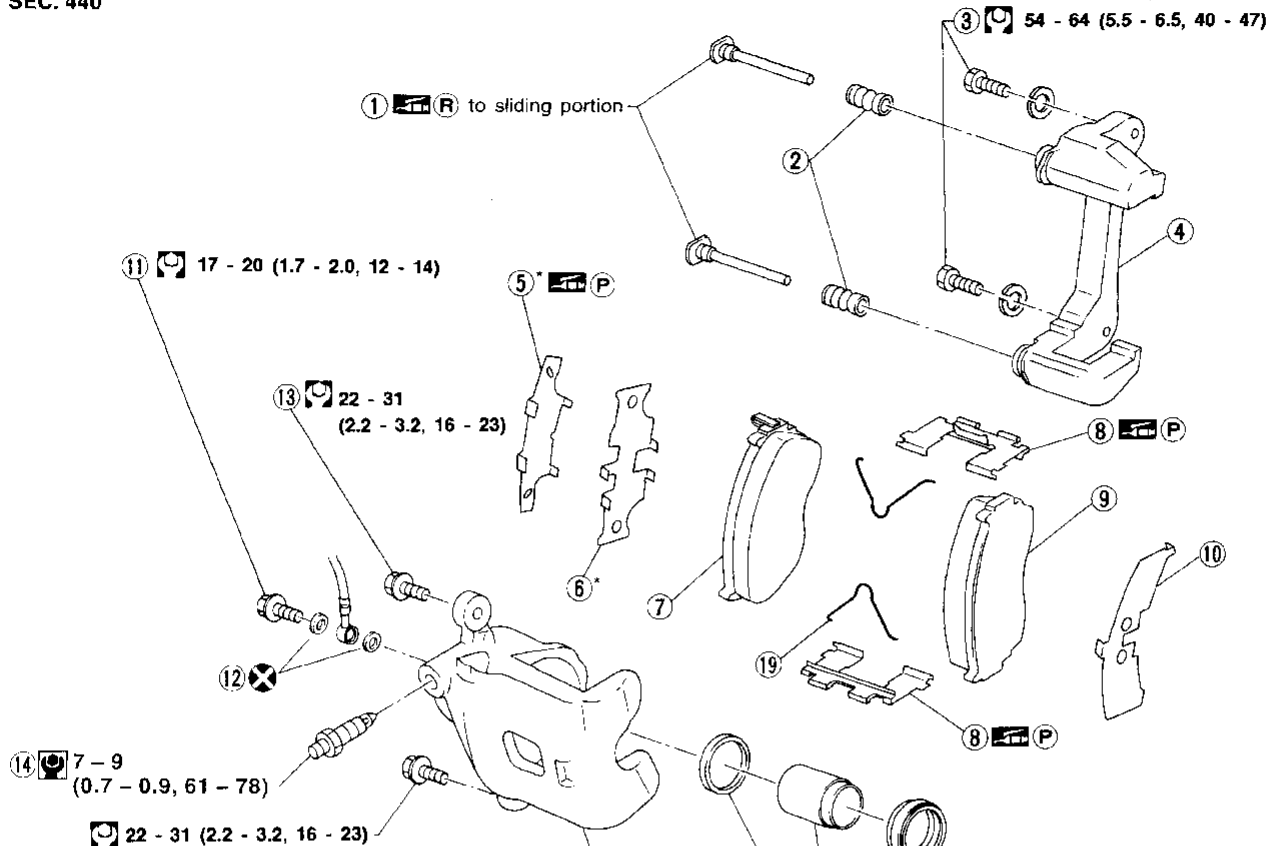

- (R) : Rubber grease point
- (B) : Brake fluid point
- : N•m (kg-m, ft-lb)
- (P) : PBC (Poly Butyl Cuprysil) grease or silicone-based grease point
- : N•m (kg-m, in-lb)
- \* : If equipped

ABR452

- |                             |                   |                     |
|-----------------------------|-------------------|---------------------|
| ① Main pin                  | ⑧ Pad retainer    | ⑭ Bleed valve       |
| ② Pin boot                  | ⑨ Outer pad       | ⑮ Cylinder body     |
| ③ Torque member fixing bolt | ⑩ Outer shim      | ⑯ Piston seal       |
| ④ Torque member             | ⑪ Connecting bolt | ⑰ Piston            |
| ⑤ Shim cover*               | ⑫ Copper washer   | ⑱ Piston boot       |
| ⑥ Inner shim*               | ⑬ Main pin bolt   | ⑲ Pad return spring |
| ⑦ Inner pad                 |                   |                     |

# FRONT DISC BRAKE

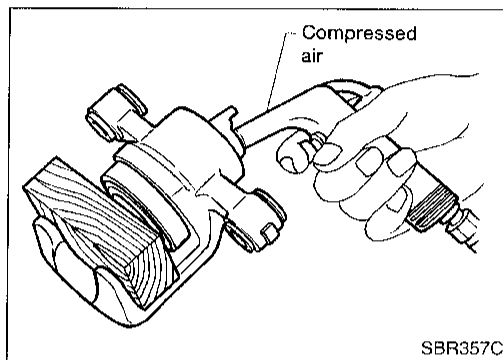
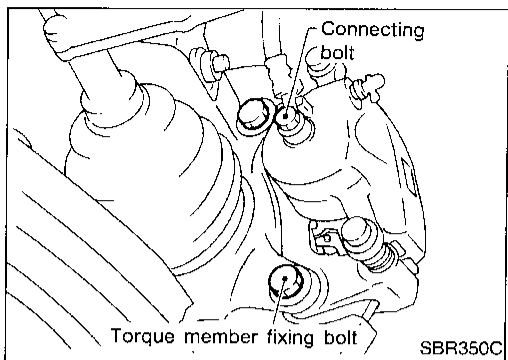

## Removal

### WARNING:

Clean brake pads with a vacuum dust collector to minimize the hazard of airborne particles or other materials.

### CAUTION:

Suspend caliper assembly with wire so as not to stretch brake hose.

Remove torque member fixing bolts and connecting bolt.

It is not necessary to remove connecting bolt except for disassembly or replacement of caliper assembly. In this case, suspend caliper assembly with wire so as not to stretch brake hose.

## Disassembly

### WARNING:

Do not place your fingers in front of piston.

### CAUTION:

Do not scratch or score cylinder wall.

1. Push out piston and boot with compressed air.
2. Remove piston seal with a suitable tool.

## Inspection — Caliper

### CYLINDER BODY

- Check inside surface of cylinder for score, rust, wear, damage or presence of foreign objects. If any of the above conditions are observed, replace cylinder body.
- Minor damage from rust or foreign objects may be eliminated by polishing surface with a fine emery paper. Replace cylinder body if necessary.

### CAUTION:

Use brake fluid to clean. Never use mineral oil.

### PISTON

Check piston for scoring, rust, wear, damage or presence of foreign objects. Replace if any of the above conditions are observed.

### CAUTION:

Piston sliding surface is plated. Do not polish with emery paper even if rust or foreign objects are stuck to sliding surface.

### SLIDE PIN, PIN BOLT AND PIN BOOT

Check for wear, cracks or other damage. Replace if any of the above conditions are observed.

GI

MA

EM

LC

EC

FE

CL

WT

AT

FA

RA

**BR**

ST

RS

BT

HA

EL

IDX

# FRONT DISC BRAKE

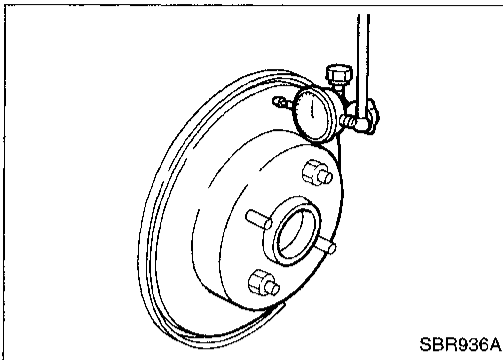

## Inspection — Rotor

### RUNOUT

1. Secure rotor to wheel hub with at least two nuts (M12 x 1.25).
2. Check runout using a dial indicator.

**Make sure that wheel bearing axial end play is within the specifications before measuring. Refer to FA section ("Front Wheel Bearing", "ON-VEHICLE SERVICE").**

**Maximum runout:  
0.07 mm (0.0028 in)**

3. If the runout is out of specification, find minimum runout position as follows:
  - a. Remove nuts and rotor from wheel hub.
  - b. Shift the rotor one hole and secure rotor to wheel hub with nuts.
  - c. Measure runout.
  - d. Repeat steps a. through c. so that minimum runout position can be found.
4. If the runout is still out of specification, turn rotor with on-car brake lathe ("MAD, DL-8700", "AMMCO 700 and 705" or equivalent).

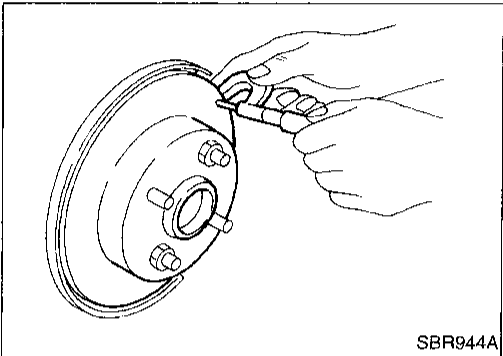

### THICKNESS

**Thickness variation (At least 8 positions):  
Maximum 0.02 mm (0.0008 in)**

If thickness variation exceeds the specification, turn rotor with on-car brake lathe.

**Rotor repair limit:  
Minimum thickness  
16.0 mm (0.630 in)**

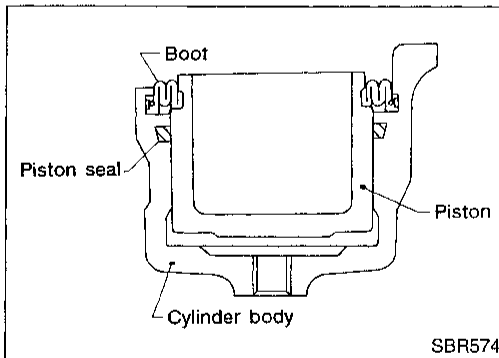

## Assembly

1. Insert piston seal into groove on cylinder body.
2. With piston boot fitted to piston, insert piston boot into groove on cylinder body and install piston.
3. Properly secure piston boot.

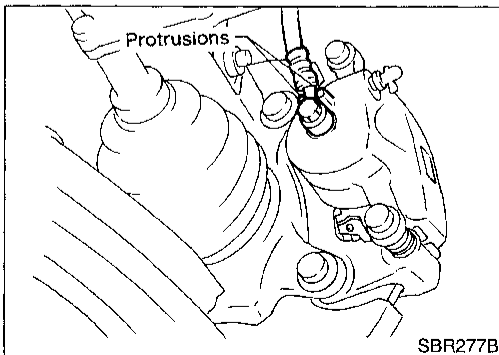

## Installation

### CAUTION:

- Refill with new brake fluid DOT 3.
  - Never reuse drained brake fluid.
1. Install caliper assembly.
  2. Install brake hose to caliper securely.
  3. Install all parts and secure all bolts.
  4. Bleed air. Refer to "Bleeding Procedure", BR-5.

## Brake Burnishing Procedure

After replacing or refinishing brake rotor, perform the following burnishing procedure of the brake pad contact surfaces.

### CAUTION:

**Due to road conditions and traffic safety, use extreme caution when performing this procedure.**

1. Drive the vehicle on a straight smooth road at 50km/h (30 MPH).
2. Use medium brake pedal/foot effort to bring the vehicle to a complete stop from 50 km/h (30 MPH). Adjust brake pedal/foot pressure such that vehicle stopping time equals 3 - 5 seconds.
3. To cool the brake system, drive the vehicle at 50 km/h (30 MPH) for 1 minute without stopping.
4. Repeat steps 1 - 3 10 times or more to complete the burnishing procedure.

GI

MA

EM

LC

EC

FE

CL

MT

AT

FA

RA

**BR**

ST

RS

BT

HA

EL

IDX

# REAR DRUM BRAKE

## Components

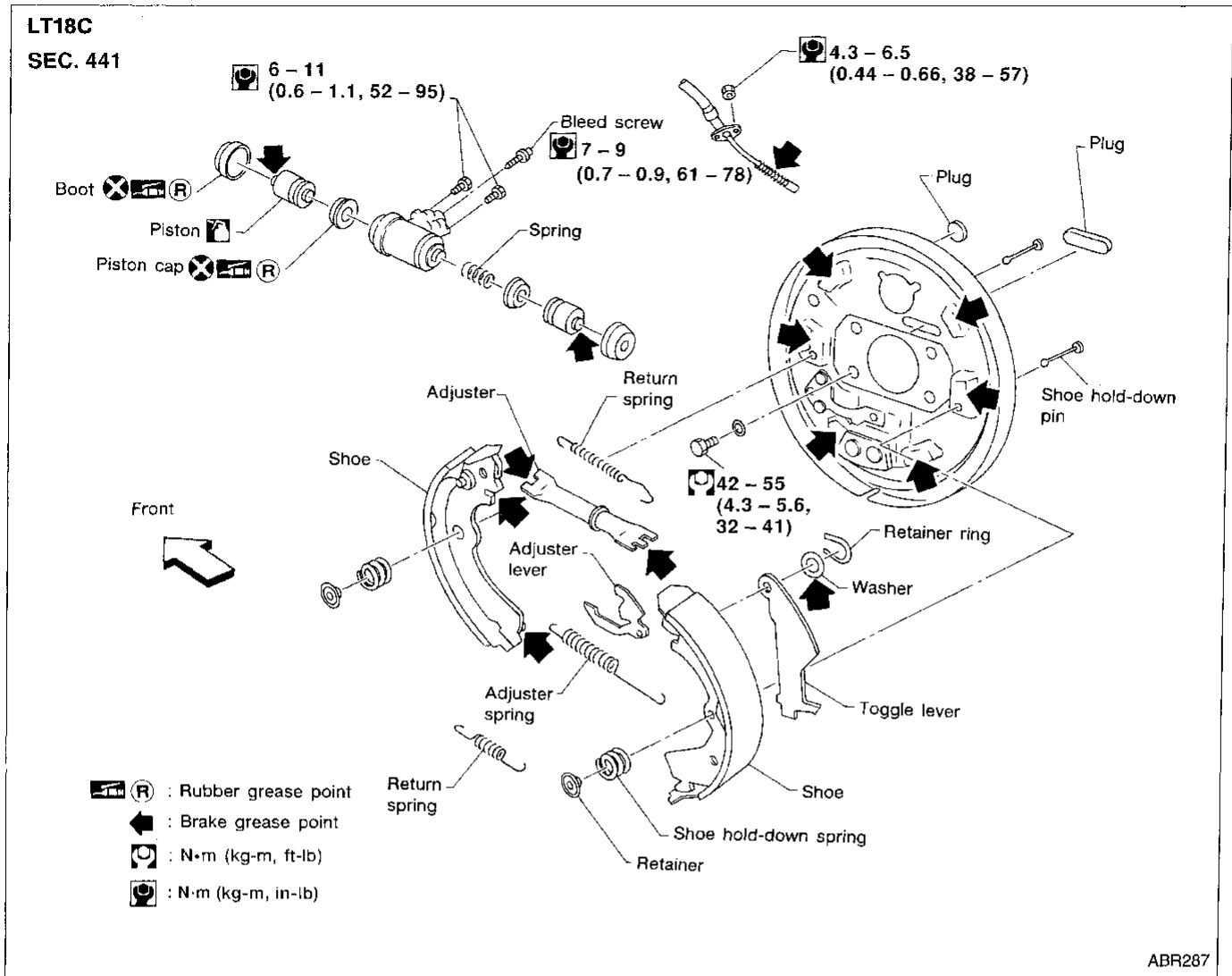

## Removal

### WARNING:

Clean brake lining with a vacuum dust collector to minimize the hazard of airborne materials.

### CAUTION:

Make sure parking brake lever is completely released.

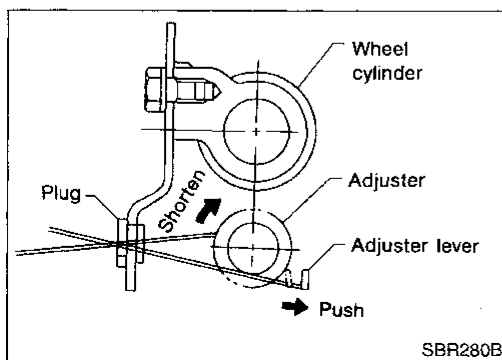

1. Release parking brake lever fully, then remove drum.  
**If drum is hard to remove, the following procedures should be carried out.**
  - a. Remove plug. Then shorten adjuster to make clearance between brake shoe and drum as shown.



# REAR DRUM BRAKE

## Removal (Cont'd)

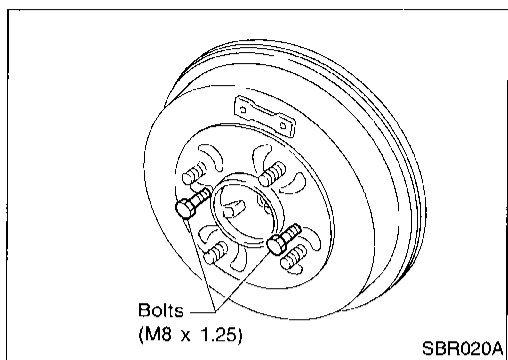

- b. Install two bolts as shown. Tighten the two bolts gradually.

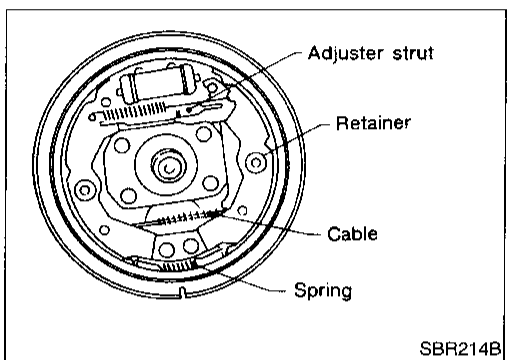

2. After removing retainer, remove spring by rotating shoes.
  - Be careful not to damage wheel cylinder piston boots.
  - Be careful not to damage parking brake cable when separating it.
3. Remove adjuster.
4. Disconnect parking brake cable from toggle lever.

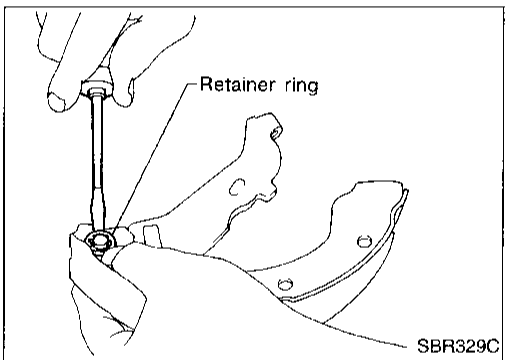

5. Remove retainer ring with a suitable tool. Then separate toggle lever and brake shoe.

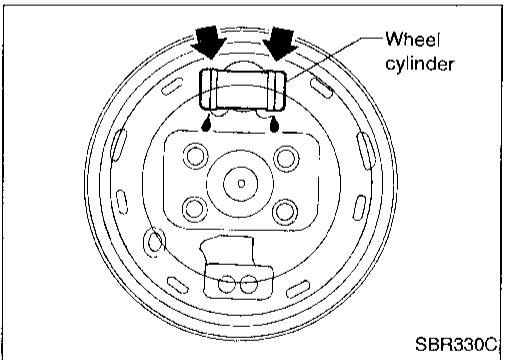

## Inspection — Wheel Cylinder

- Check wheel cylinder for leakage.
- Check for wear, damage and loose conditions. Replace if any such condition exists.

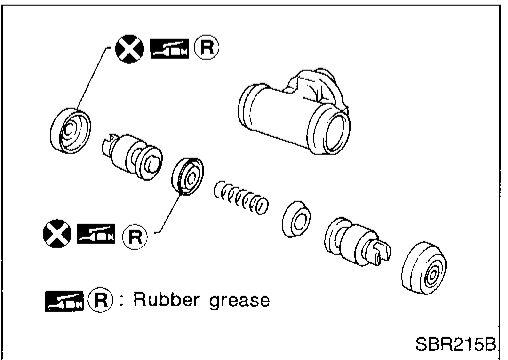

## Wheel Cylinder Overhaul

- Check all internal parts for wear, rust and damage. Replace if necessary.
- Pay attention so as not to scratch cylinder when installing pistons.

GI

MA

EM

LC

EC

FE

CL

MT

AT

FA

RA

**BR**

ST

RS

BT

HA

EL

IDX

# REAR DRUM BRAKE

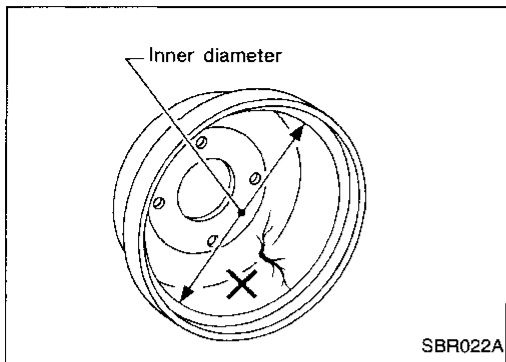

## Inspection — Drum

**Maximum inner diameter:**

**181 mm (7.13 in)**

**Maximum out-of-round:**

**0.03 mm (0.0012 in)**

- Contact surface should be fine finished with No. 120 to 150 emery paper.
- Using a drum lathe, resurface brake drum if it shows scoring, partial wear or stepped wear.
- After brake drum has been completely reconditioned or replaced, check drum and shoes for proper contact pattern.

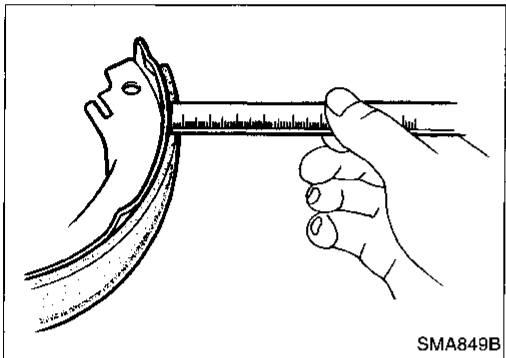

## Inspection — Lining

Check lining thickness.

**Standard lining thickness:**

**4.0 mm (0.16 in)**

**Lining wear limit:**

**1.5 mm (0.059 in)**

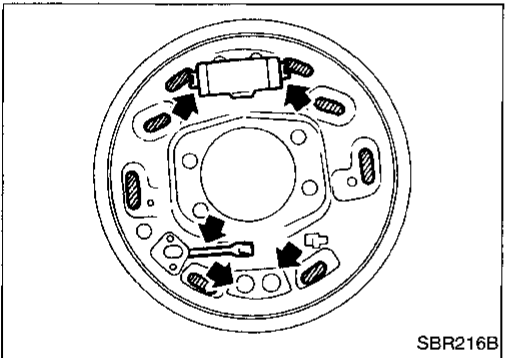

## Installation

**Always perform shoe clearance adjustment. Refer to BR-36.**

1. Fit toggle lever to brake shoe with retainer ring.
2. Apply brake grease to the contact areas shown at left.

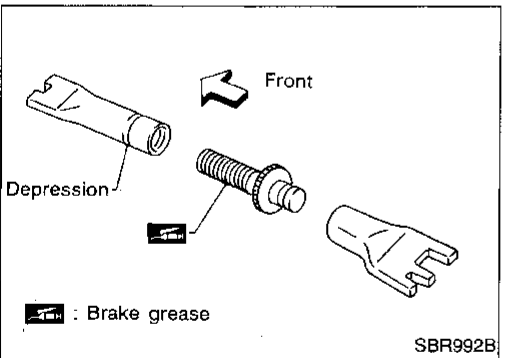

3. Shorten adjuster by rotating it.
- Pay attention to direction of adjuster.

Wheel	Screw	Depression
Left	Left-hand thread	Yes
Right	Right-hand thread	No

4. Connect parking brake cable to toggle lever.
5. Install all parts.

**Be careful not to damage wheel cylinder piston boots.**

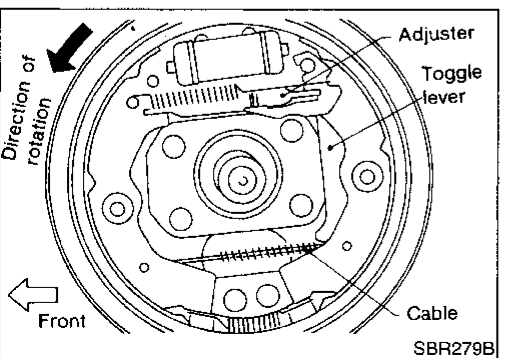

6. Check all parts are installed properly.

**Pay attention to direction of adjuster assembly.**

7. Install brake drum.
8. When installing new wheel cylinder or overhauling wheel cylinder, bleed air. Refer to "Bleeding Procedure", BR-5.
9. Adjust parking brake. Refer to BR-36.

# REAR DISC BRAKE

## Pad Replacement

### WARNING:

Clean brake pads with a vacuum dust collector to minimize the hazard of airborne materials.

### CAUTION:

- When cylinder body is open, do not depress brake pedal, otherwise caliper piston will pop out.
- Be careful not to damage piston boot or get oil on rotor. Always replace shims when replacing pads.
- If shims are rusted or show peeling of rubber coat, replace them with new shims.
- It is not necessary to remove connecting bolt except for disassembly or replacement of caliper assembly. In this case, suspend cylinder body with wire so as not to stretch brake hose.
- Carefully monitor brake fluid level because brake fluid will return to reservoir when pushing back piston.

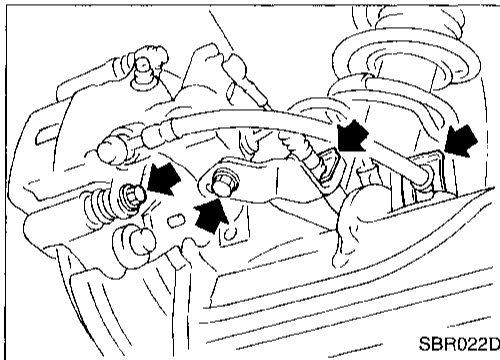

1. Remove master cylinder reservoir cap.
2. Remove brake cable lock spring.
3. Remove cable guide from caliper assembly.
4. Disconnect cable.
5. Remove lock spring from brake hose. Then remove brake hose from bracket.
6. Remove lower pin bolt.
7. Open cylinder body upward. Then remove pad retainers, and inner and outer shims.

**Standard pad thickness:**

**10 mm (0.39 in)**

**Pad wear limit:**

**1.5 mm (0.059 in)**

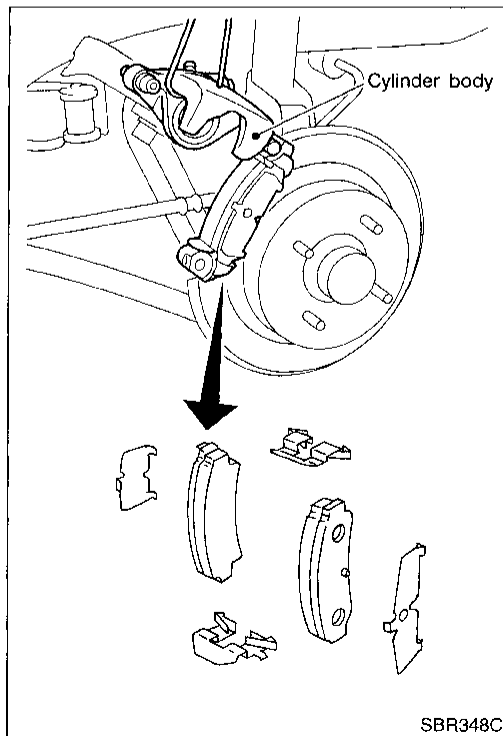

## REAR DISC BRAKE

### Pad Replacement (Cont'd)

- When installing new pads, push piston into cylinder body by turning piston clockwise.

**Carefully monitor brake fluid level because brake fluid will return to reservoir when pushing back piston.**

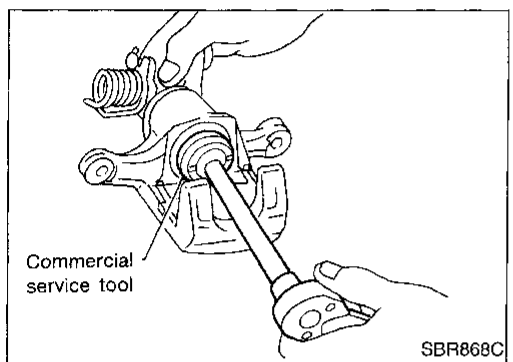
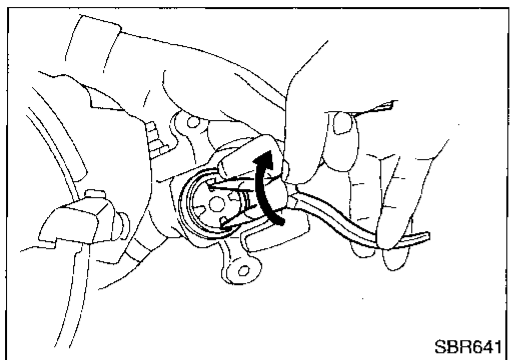

# REAR DISC BRAKE

## Components

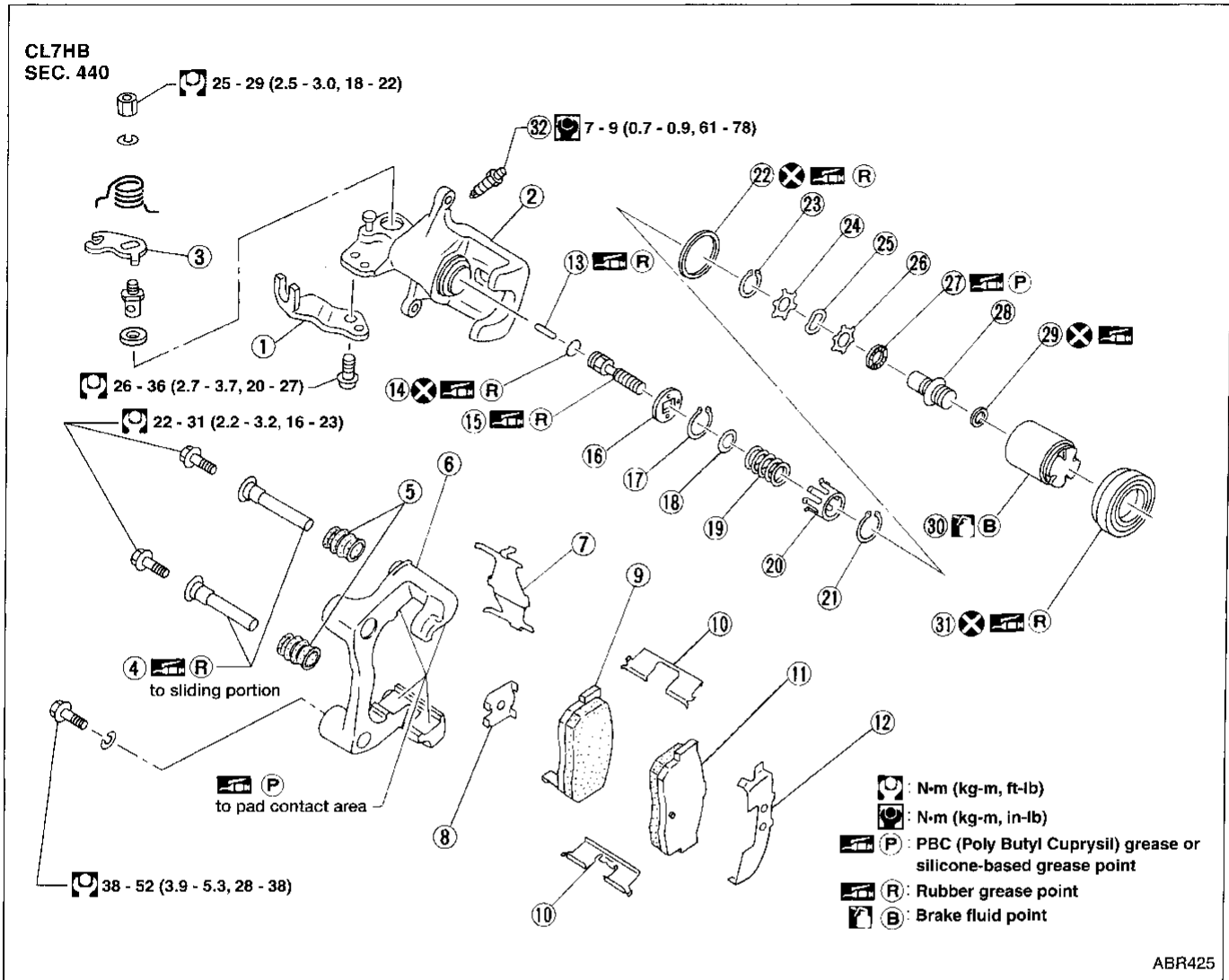

- ① Cable guide
- ② Cylinder body
- ③ Toggle lever
- ④ Pin
- ⑤ Pin boot
- ⑥ Torque member
- ⑦ Retainer
- ⑧ Inner shim
- ⑨ Inner pad
- ⑩ Pad retainer
- ⑪ Outer pad

- ⑫ Outer shim
- ⑬ Strut
- ⑭ O-ring
- ⑮ Push rod
- ⑯ Key plate
- ⑰ Snap ring
- ⑱ Seat
- ⑲ Spring
- ⑳ Spring cover
- ㉑ Snap ring
- ㉒ Piston seal

- ㉓ Snap ring
- ㉔ Spacer
- ㉕ Wave washer
- ㉖ Spacer
- ㉗ Bearing
- ㉘ Adjuster
- ㉙ Cup
- ㉚ Piston
- ㉛ Piston boot
- ㉜ Air bleeder

GI  
MA  
EM  
LC  
EC  
FE  
CL  
MT  
AT  
FA  
RA  
BR  
ST  
RS  
BT  
HA  
EL  
IDX

# REAR DISC BRAKE

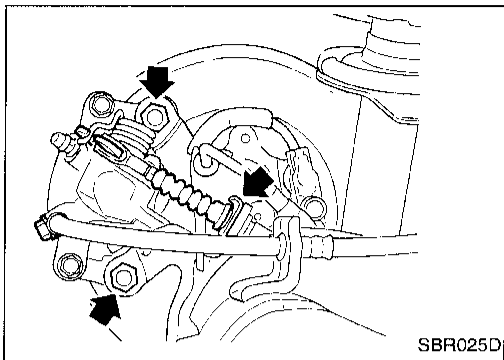

## Removal

### WARNING:

Clean brake pads with a vacuum dust collector to minimize the hazard of airborne particles or other materials.

1. Remove parking brake cable lock plate.
2. Remove torque member fixing bolts and connecting bolt.

It is not necessary to remove connecting bolt except for disassembly or replacement of caliper assembly. In this case, suspend caliper assembly with wire so as not to stretch brake hose.

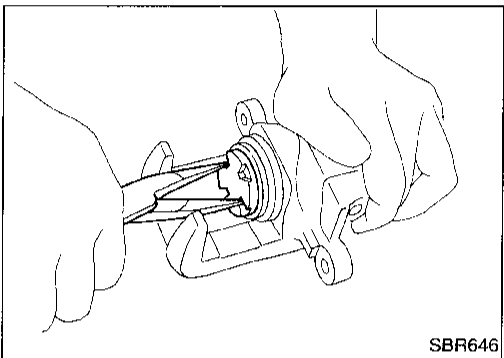

## Disassembly

1. Remove piston by turning it counterclockwise with suitable long nose pliers or commercial service tool.

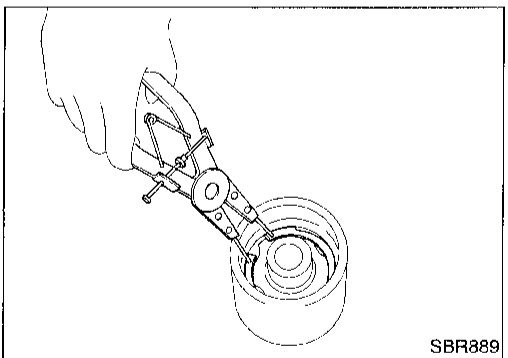
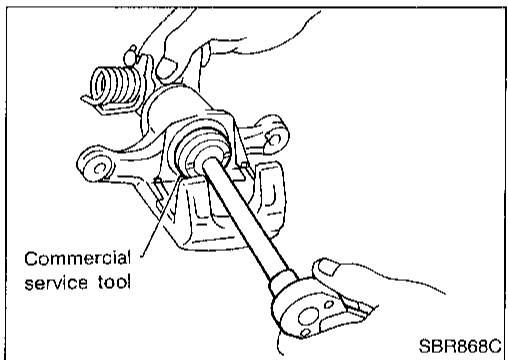

2. Remove snap ring from piston with suitable pliers and remove adjusting nut.

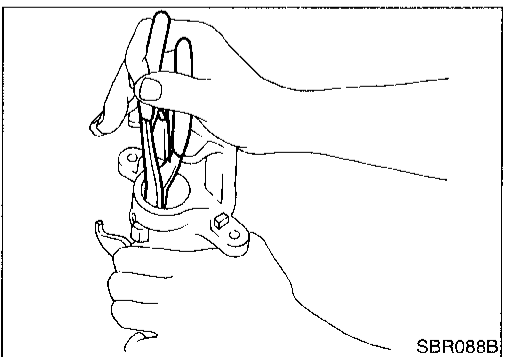

3. Disassemble cylinder body.
  - a. Pry off snap ring with suitable pliers, then remove spring cover, spring and seat.
  - b. Remove snap ring, then remove key plate, push rod and strut.

## REAR DISC BRAKE

### Disassembly (Cont'd)

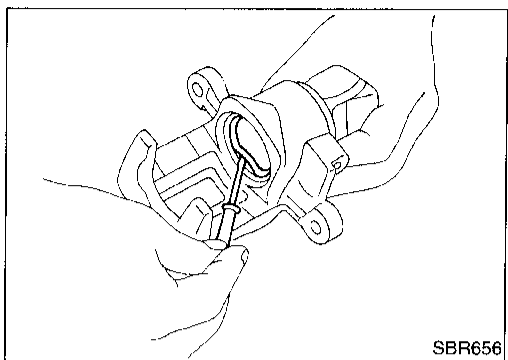

SBR656

- c. Remove piston seal.  
**Be careful not to damage cylinder body.**

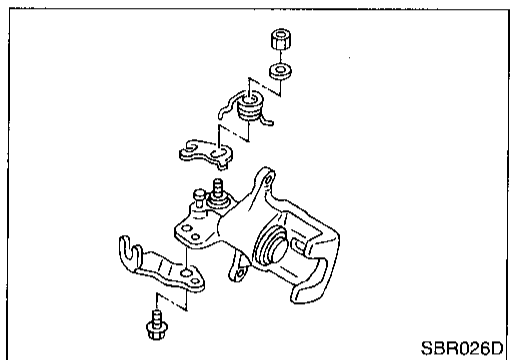

SBR026D

4. Remove return spring, toggle lever and cable guide.

### Inspection — Caliper

#### CAUTION:

**Use brake fluid to clean cylinder. Never use mineral oil.**

#### CYLINDER BODY

- Check inside surface of cylinder for scoring, rust, wear, damage or presence of foreign objects. If any of the above conditions are observed, replace cylinder body.
- Minor damage from rust or foreign objects may be eliminated by polishing surface with a fine emery paper. Replace cylinder body if necessary.

#### TORQUE MEMBER

Check for wear, cracks or other damage. Replace if necessary.

#### PISTON

##### CAUTION:

**Piston sliding surface is plated. Do not polish with emery paper even if rust or foreign objects are stuck to sliding surface.**

Check piston for score, rust, wear, damage or presence of foreign objects. Replace if any of the above conditions are observed.

#### SLIDE PIN, PIN BOLT, AND PIN BOOT

Check for wear, cracks or other damage.

Replace if any of the above conditions are observed.

GI

MA

EM

LC

EC

FE

CL

MT

AT

FA

RA

**BR**

ST

RS

BT

HA

EL

IDX

# REAR DISC BRAKE

## Inspection — Rotor

### RUBBING SURFACE

Check rotor for roughness, cracks or chips.

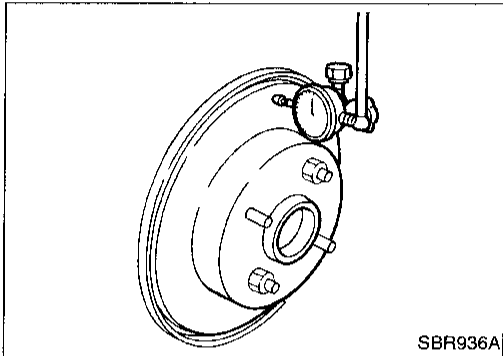

### RUNOUT

1. Secure rotor to wheel hub with at least two nuts (M12 x 1.25).
2. Check runout using a dial indicator.

**Make sure that wheel bearing axial end play is within the specifications before measuring. Refer to RA section (“Rear Wheel Bearing”, “ON-VEHICLE SERVICE”).**

3. Change relative positions of rotor and wheel hub so that runout is minimized.

**Maximum runout:  
0.07 mm (0.0028 in)**

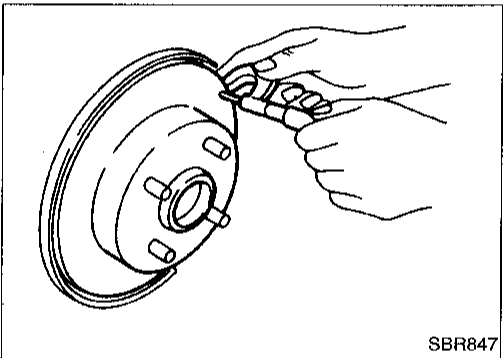

### THICKNESS

**Rotor repair limit:  
Minimum thickness  
6.0 mm (0.236 in)**

**Thickness variation (At least 8 positions)  
Maximum 0.02 mm (0.0008 in)**

Replace rotor if any of the above do not meet the specifications.

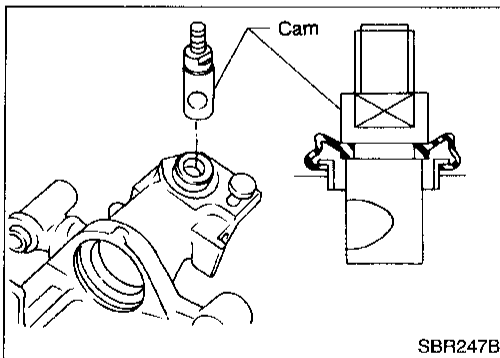

### Assembly

1. Insert cam with depression facing towards open end of cylinder.

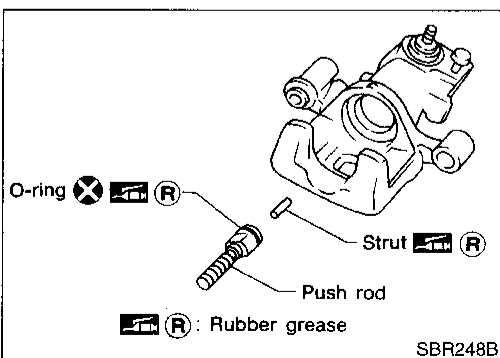

2. Generously apply rubber grease to strut and push rod to make insertion easy.



# REAR DISC BRAKE

## Assembly (Cont'd)

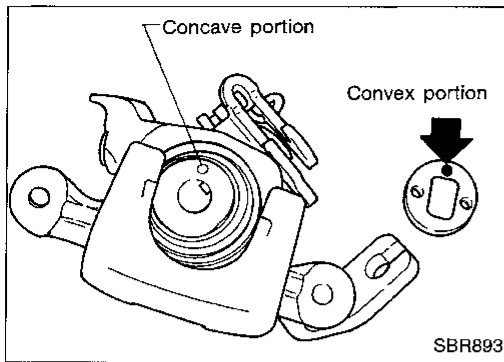

3. Match protrusion on key plate with depression in cylinder.

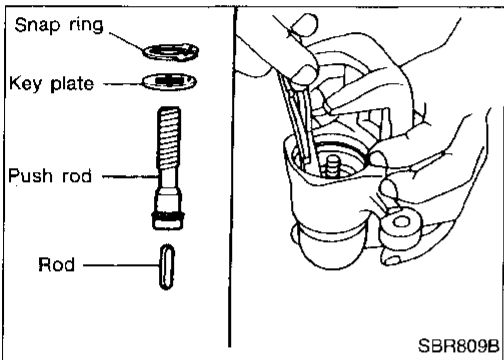

4. Install snap ring with a suitable tool.

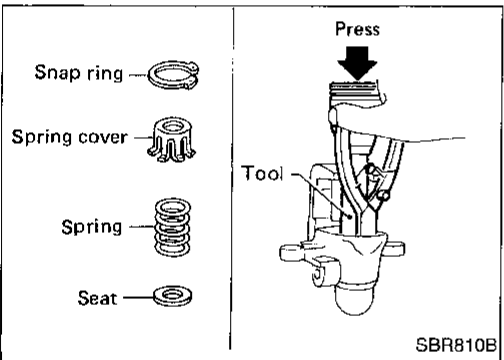

5. Install seat, spring, spring cover and snap ring while depressing with a suitable tool.

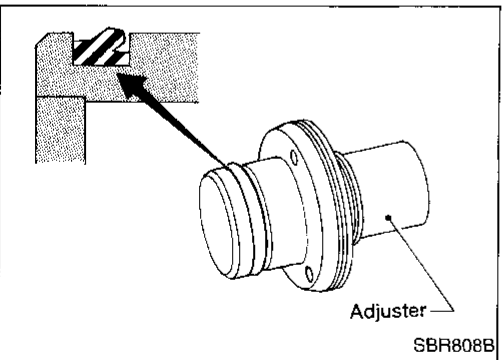

6. Install adjuster in the specified direction.

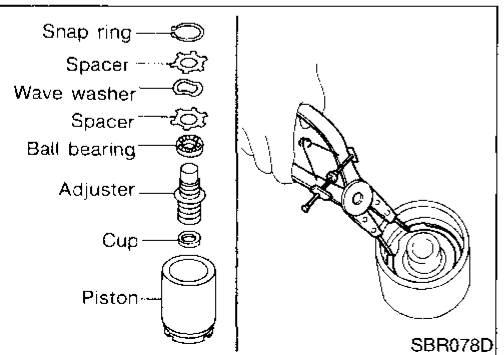

7. Install cup, adjuster, bearing, spacers, washer and snap ring with a suitable tool.

GI

MA

EM

LC

EC

FE

CL

MT

AT

FA

RA

**BR**

ST

RS

BT

HA

EL

IDX

## REAR DISC BRAKE

### Assembly (Cont'd)

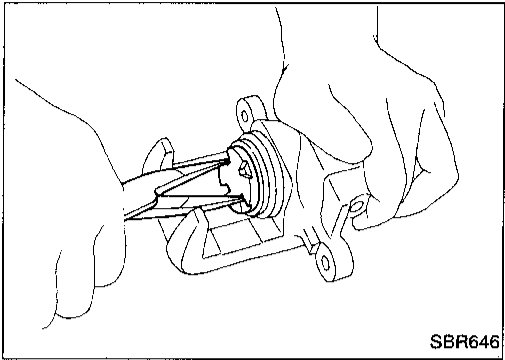

8. Insert piston seal into groove on cylinder body.
9. With piston boot fitted to piston, insert piston boot into groove on cylinder body and fit piston by turning it clockwise with long nose pliers, or suitable tool.

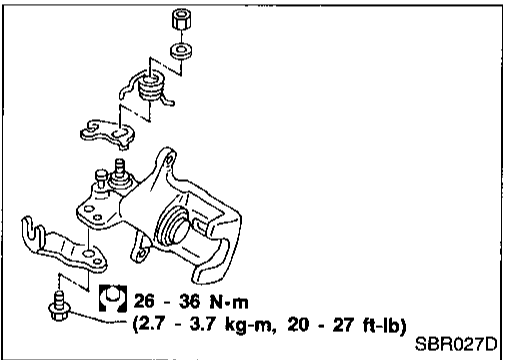
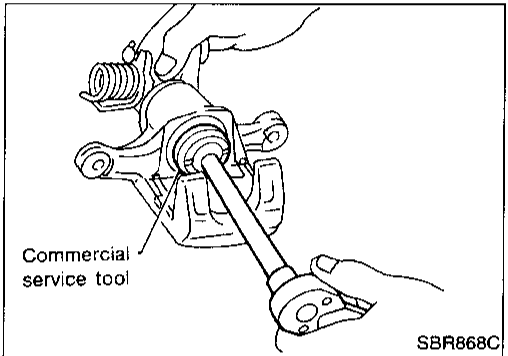

10. Fit toggle lever, return spring and cable guide.

### Installation

#### CAUTION:

- Refill with new brake fluid DOT 3.
  - Never reuse drained brake fluid.
1. Install caliper assembly.
  2. Install brake hose to caliper securely.
  3. Install all parts and secure all bolts.
  4. Bleed air. Refer to "Bleeding Procedure", BR-5.



# PARKING BRAKE CONTROL

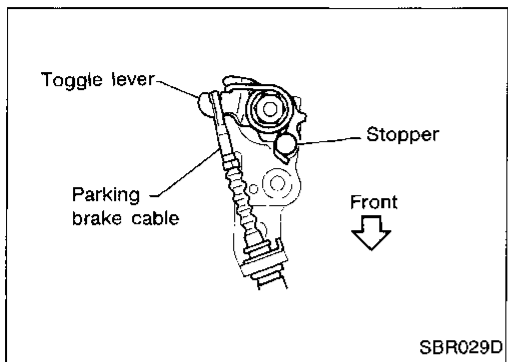

## Adjustment

Before or after adjustment, pay attention to the following points.

- For rear disc brake be sure toggle lever returns to stopper when parking brake lever is released.
- Be sure there is no drag when parking brake lever is released.

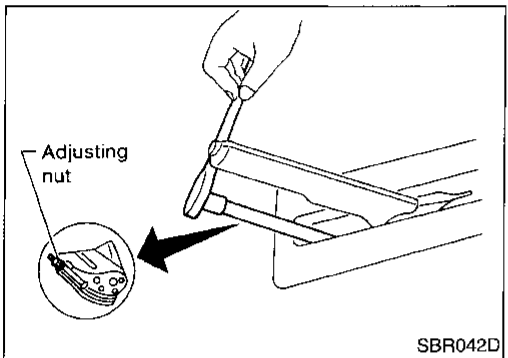

1. Adjust clearance between shoe and drum/pad and rotor as follows.
  - a. Release parking brake lever and loosen adjusting nut.
  - b. Depress brake pedal fully at least 10 times with engine running.
2. Pull control lever 4 - 5 notches. Then adjust control lever by turning adjusting nut.

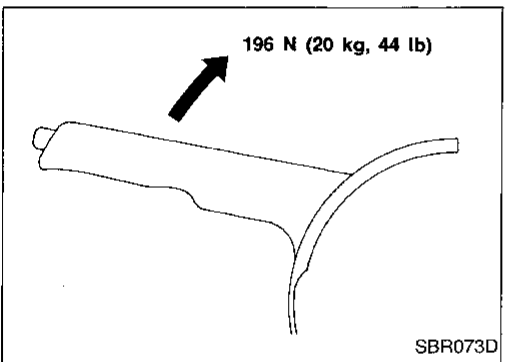

3. Pull control lever with specified amount of force. Check lever stroke and ensure smooth operation.

### Number of notches:

**Drum brake: 7 - 8**

**Disc brake: 8 - 9**

4. Bend warning lamp switchplate to ensure that:
  - Warning lamp comes on when lever is lifted "A" notches.
  - Warning lamp goes out when lever is fully released.

**Number of "A" notches : 1 or less**

# ANTI-LOCK BRAKE SYSTEM

## Purpose

The Anti-Lock Brake System (ABS) consists of electronic and hydraulic components. It allows for control of braking force so locking of the wheels can be avoided.

The ABS:

- 1) Improves proper tracking performance through steering wheel operation.
- 2) Eases obstacle avoidance through steering wheel operation.
- 3) Improves vehicle stability.

## Operation

- When the vehicle speed is less than 10 km/h (6 MPH) this system does not work.
- The Anti-Lock Brake System (ABS) has a self-test function. The system turns on the ABS warning lamp for 1 second each time the ignition switch is turned "ON". After the engine is started, the ABS warning lamp turns off. The system performs a test the first time the vehicle reaches 6 km/h (4 MPH). A mechanical noise may be heard as the ABS performs this self-test. This is a normal part of the self-test feature. If a malfunction is found during this check, the ABS warning lamp will stay on.
- While driving, a mechanical noise may be heard during ABS operation. This is a normal condition.

## ABS Hydraulic Circuit

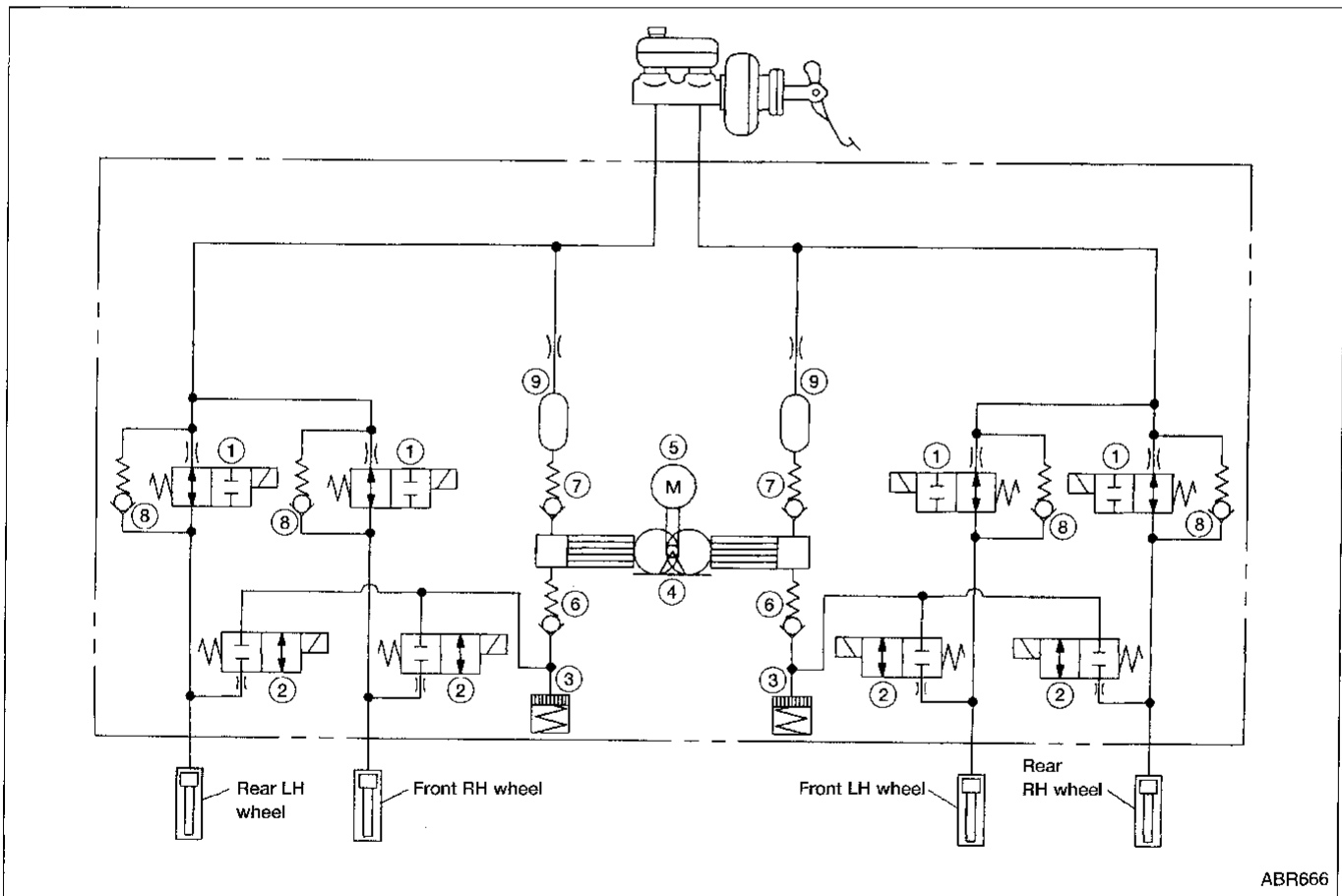

- |                         |               |                       |
|-------------------------|---------------|-----------------------|
| ① Inlet solenoid valve  | ④ Pump        | ⑦ Outlet valve        |
| ② Outlet solenoid valve | ⑤ Motor       | ⑧ By-pass check valve |
| ③ Reservoir             | ⑥ Inlet valve | ⑨ Damper              |

# ANTI-LOCK BRAKE SYSTEM

## System Components

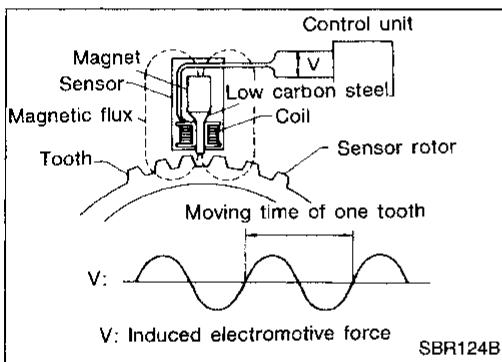
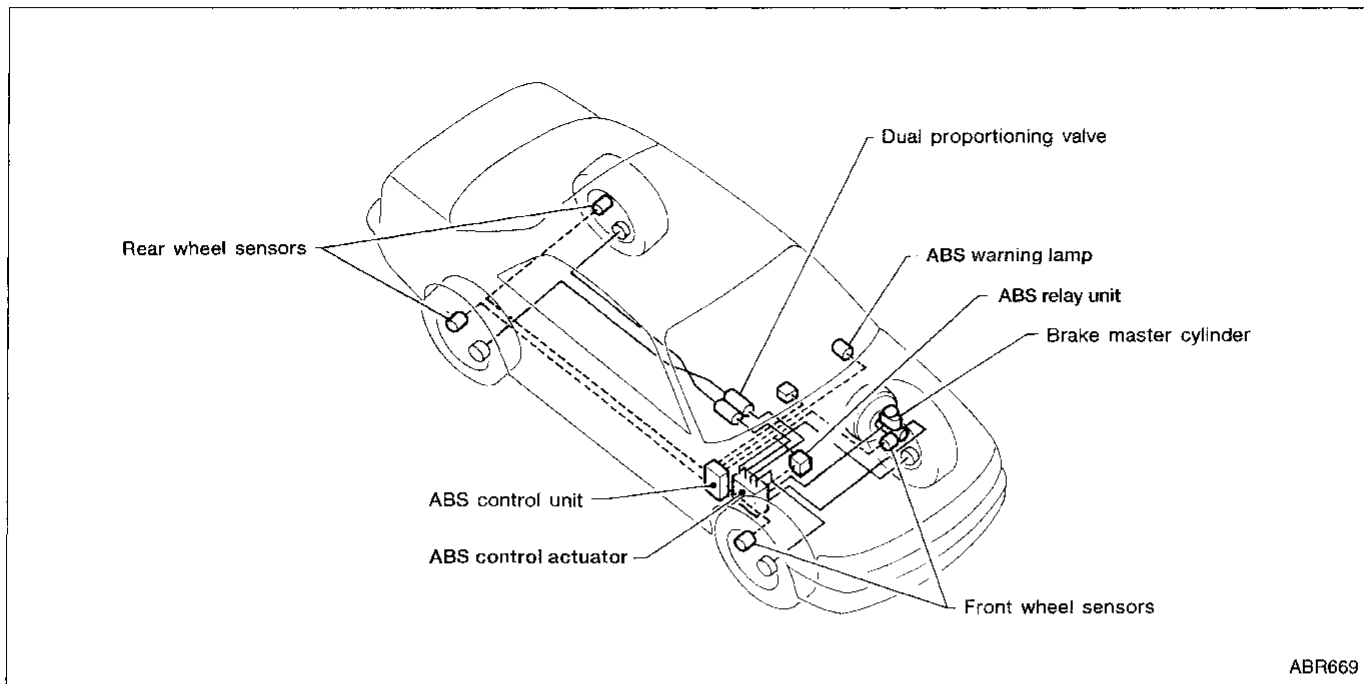

## System Description

### SENSOR

The sensor unit consists of a gear-shaped sensor rotor and a sensor element. The element contains a bar magnet around which a coil is wound. The sensor is installed on the back side of the brake rotor. Sine-wave current is generated by the sensor as the wheel rotates. The frequency and voltage increase(s) as the rotating speed increases.

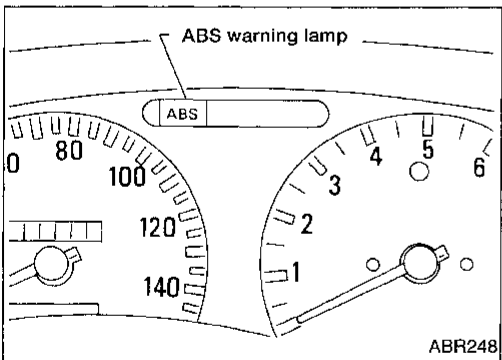

### CONTROL UNIT

The control unit computes the wheel rotating speed by the signal current sent from the sensor. Then it supplies a DC current to the actuator solenoid valve. It also controls ON-OFF operation of the valve relay and motor relay. If an electrical malfunction is detected in the system, the control unit causes the warning lamp to light up. In this condition, the ABS will be deactivated by the control unit, and the vehicle's brake system reverts to normal operation.

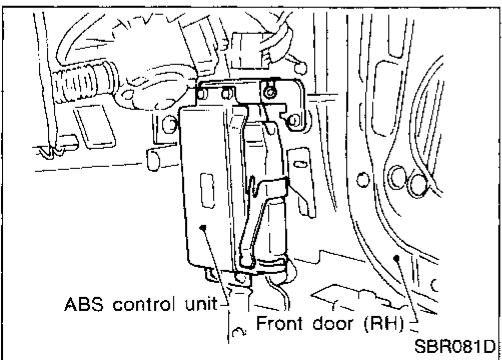

# ANTI-LOCK BRAKE SYSTEM

## System Description (Cont'd)

### ACTUATOR

The actuator contains:

- An electric motor and pump
- Two relays
- Eight solenoid valves, each inlet and outlet for
  - LH front
  - RH front
  - LH rear
  - RH rear

These components control the hydraulic circuit. The ABS control unit directs the actuator to increase, hold or decrease hydraulic pressure to all or individual wheels.

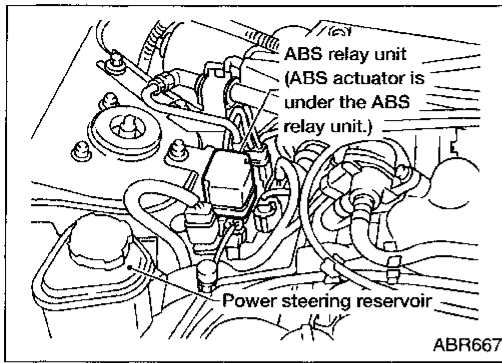

### ABS actuator operation

		Inlet solenoid valve	Outlet solenoid valve	
Normal brake operation		OFF (Open)	OFF (Closed)	Master cylinder brake fluid pressure is directly transmitted to caliper via the inlet solenoid valve.
ABS operation	Pressure hold	ON (Closed)	OFF (Closed)	Hydraulic circuit is shut off to hold the caliper brake fluid pressure.
	Pressure decrease	ON (Closed)	ON (Open)	Caliper brake fluid is sent to reservoir via the outlet solenoid valve. Then it is pushed up to the master cylinder by pump.
	Pressure increase	OFF (Open)	OFF (Closed)	Master cylinder brake fluid pressure is transmitted to caliper.

GI

MA

EM

LC

EC

FE

CL

MT

AT

FA

RA

**BR**

ST

RS

BT

HA

EL

IDX

# ANTI-LOCK BRAKE SYSTEM

## Removal and Installation

### CAUTION:

Be careful not to damage sensor edge and sensor rotor teeth.

When removing the front or rear wheel hub assembly, disconnect the ABS wheel sensor from the assembly and move it away.

## FRONT WHEEL SENSOR

SEC. 476

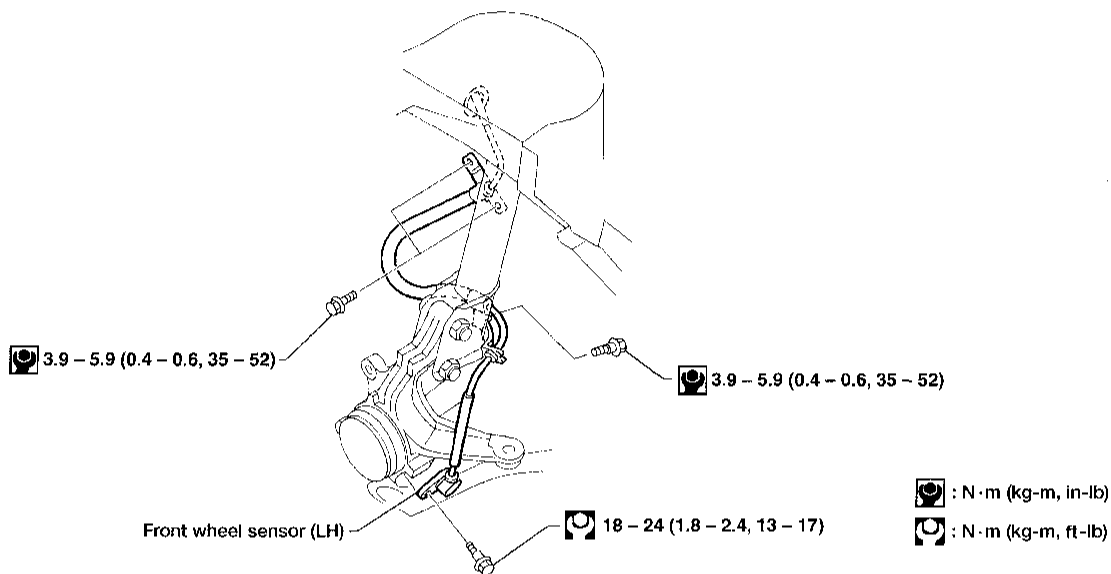

ABR668

## REAR WHEEL SENSOR

SEC. 476

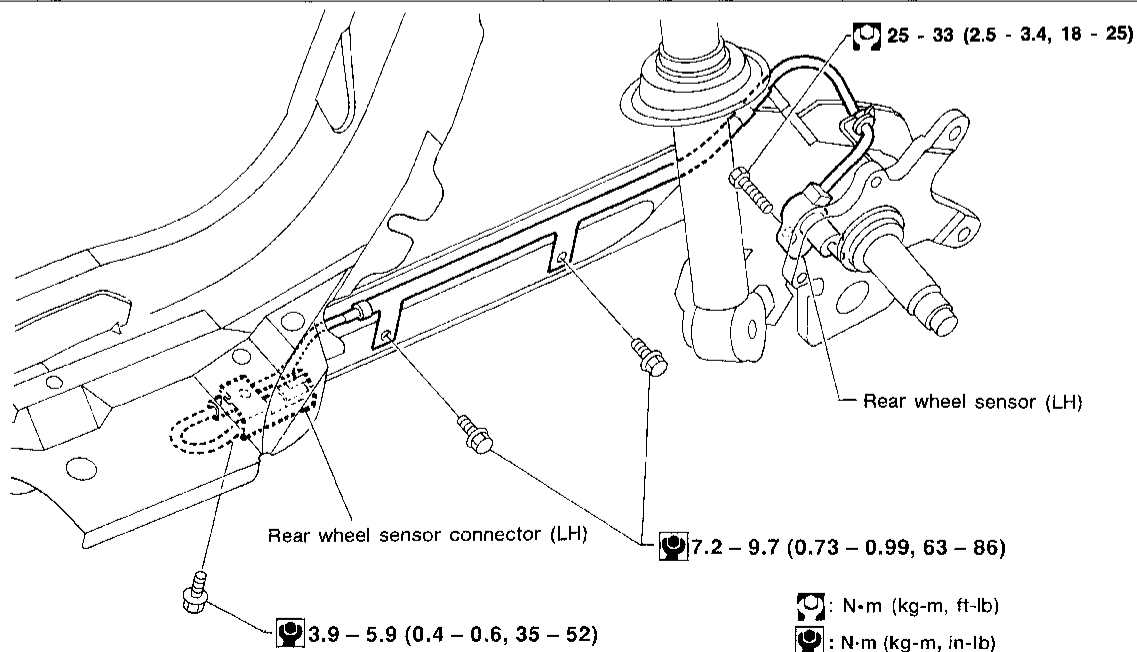

ABR291



# ANTI-LOCK BRAKE SYSTEM

## Removal and Installation (Cont'd)

### SENSOR ROTOR

#### Removal

1. Remove the drive shaft and rear wheel hub. Refer to FA section ("Drive Shaft", "FRONT AXLE.") and RA section ("Wheel Hub", "REAR AXLE.")
2. Remove the sensor rotor using suitable puller, drift and bearing replacer.

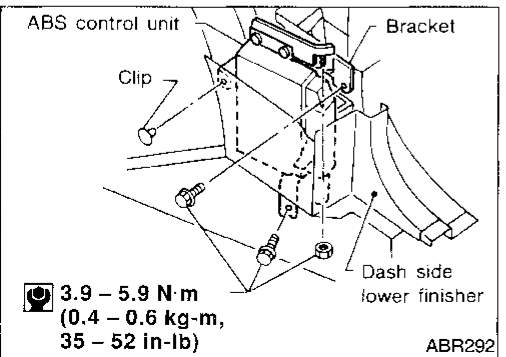
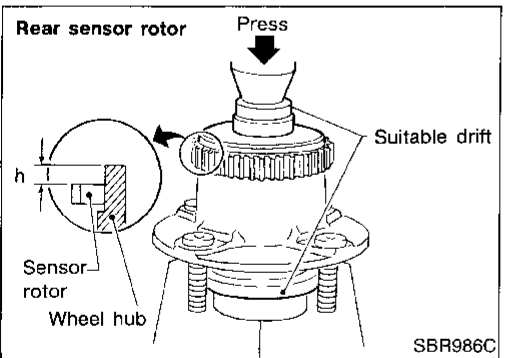
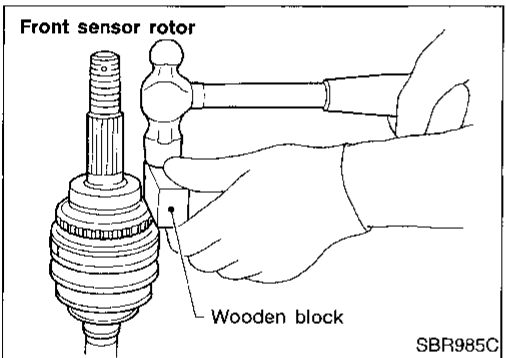
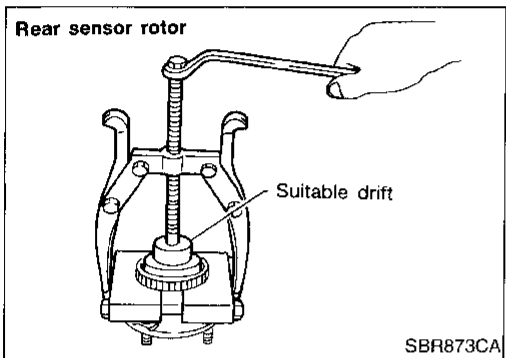
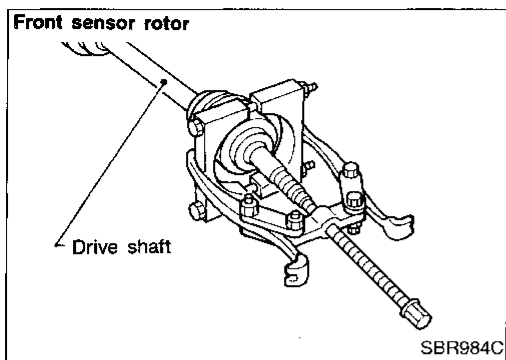

#### Installation

Install the sensor rotor. For front sensor rotor, use hammer and wooden block. For rear sensor rotor, use suitable drift and press.

- Always replace sensor rotor with new one.

- Pay attention to the dimension of rear sensor rotor as shown in figure.

**h: 4.5 - 5.5 mm (0.177 - 0.217 in)**

#### CONTROL UNIT

Location: Passenger side, behind dash side lower finisher.

- Make sure that the sensor shield ground cable is secured with mounting bolt.

GI  
MA  
EM  
LC  
EC  
FE  
CL  
MT  
AT  
FA  
RA  
**BR**  
ST  
RS  
BT  
HA  
EL  
IOX

# ANTI-LOCK BRAKE SYSTEM

## Removal and Installation (Cont'd)

### ABS CONTROL ACTUATOR

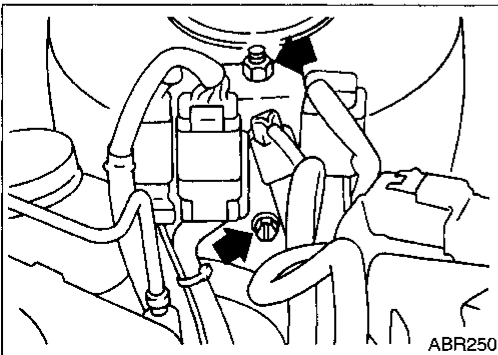
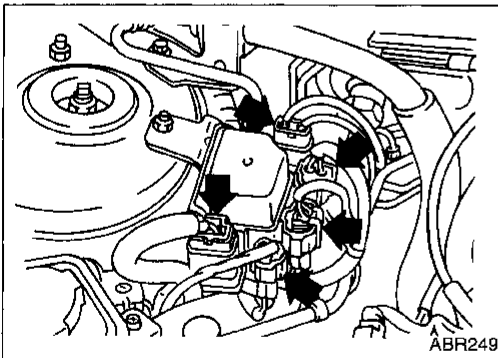
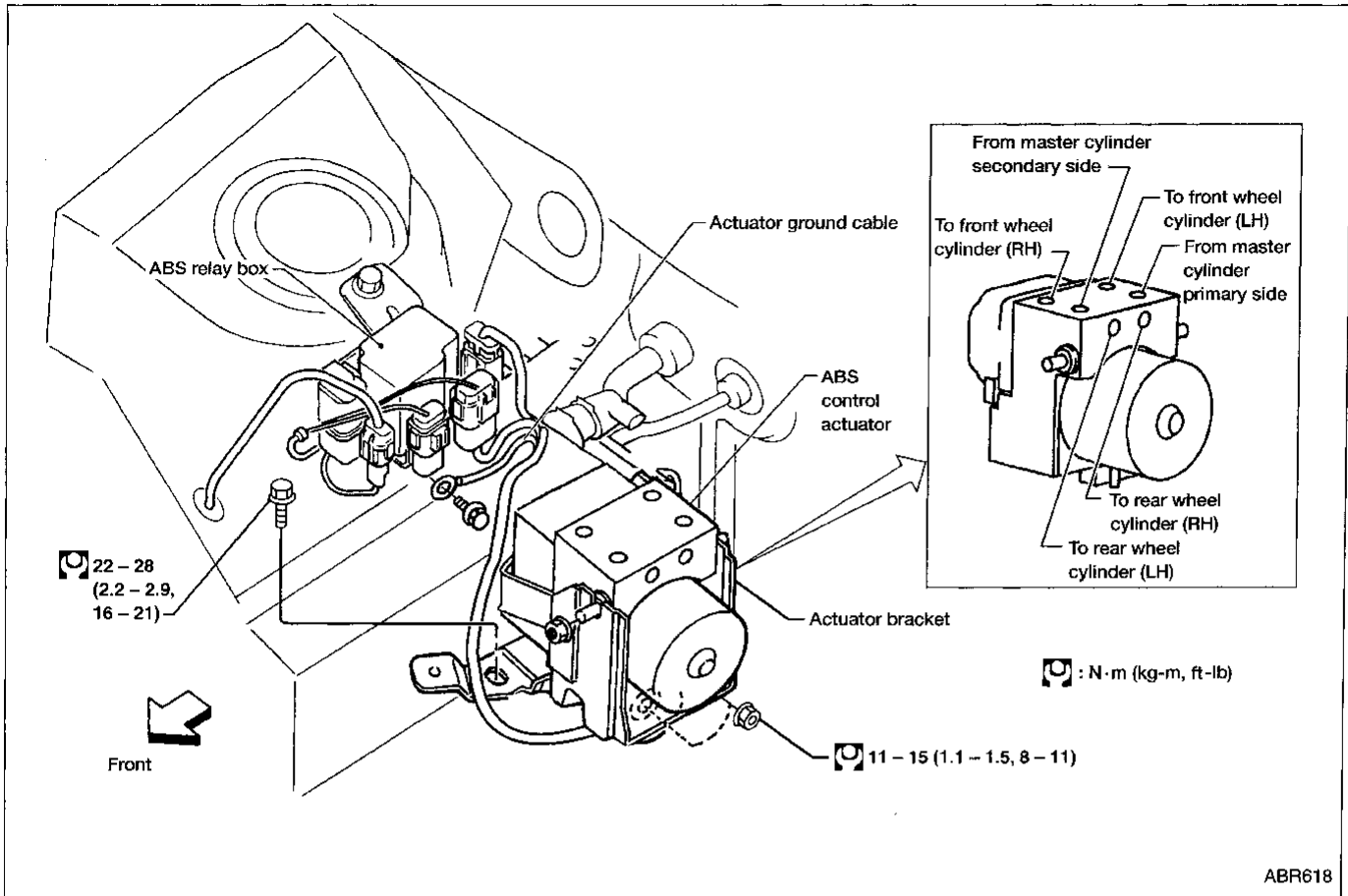

1. Disconnect battery cable.
2. Drain brake fluid. Refer to BR-4.
3. Discharge air conditioner refrigerant. Refer to HA section ("R-134a Service Procedure", "SERVICE PROCEDURES").
4. Disconnect all connectors from ABS relay unit.

5. Remove ABS relay unit with bracket.
6. Remove air conditioner low-pressure tubes. Refer to HA section, ("Refrigerant Lines", "SERVICE PROCEDURES").
7. Disconnect and separate brake lines and move away from control actuator.

**It is not necessary to remove these lines from vehicle.**

8. Remove ABS actuator.

# ANTI-LOCK BRAKE SYSTEM

## Removal and Installation (Cont'd)

### CAUTION:

After installation, pay attention to the following points:

- Apply soapy water to rubber bushing when installing.
- Refill brake fluid and bleed air. Refer to "CHECK AND ADJUSTMENT", BR-4 and "AIR BLEEDING", BR-5.
- Charge air conditioner with refrigerant. Refer to HA section, ("R-134a Service Procedure", "SERVICE PROCEDURES").
- The installation procedure is the reverse of removal.

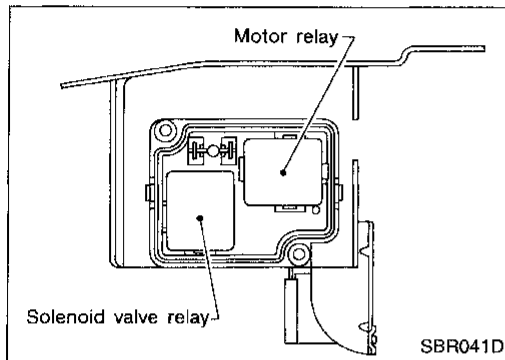

### ABS RELAYS

1. Disconnect negative battery cable.
2. Remove ABS relay unit cover.

GI

MA

EM

LC

EC

FE

CL

MT

AT

FA

RA

**BR**

ST

RS

BT

HA

EL

IDX

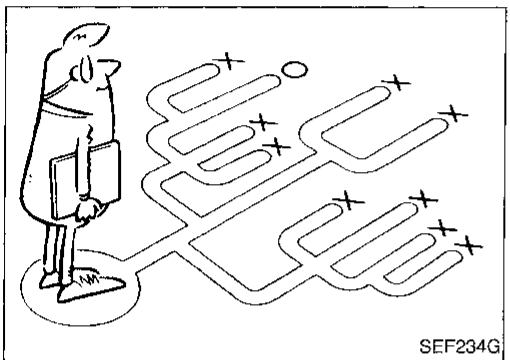
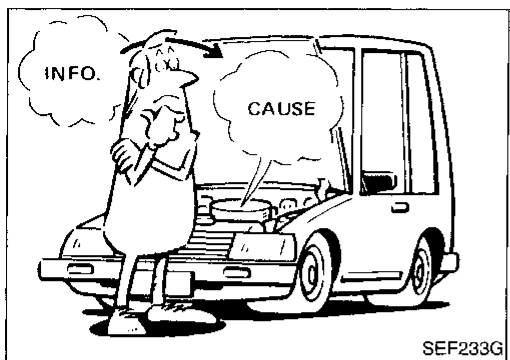

## How to Perform Trouble Diagnoses for Quick and Accurate Repair

### INTRODUCTION

The ABS system has an electronic control unit to control major functions. The control unit accepts input signals from sensors and instantly drives the actuators. It is essential that both kinds of signals are proper and stable. It is also important to check for conventional problems such as air leaks in booster lines, lack of brake fluid, or other problems with the brake system.

It is much more difficult to diagnose a problem that occurs intermittently rather than continuously. Most intermittent problems are caused by poor electric connections or faulty wiring. In this case, careful checking of suspicious circuits may help prevent the replacement of good parts.

A visual check may not find the cause of the problems, so a road test should be performed too.

Before performing actual checks, take a few minutes to talk with a customer who approaches with an ABS complaint. The customer is a very good source of information; especially for intermittent problems. By talking to the customer, find out what symptoms are present and under what conditions they occur.

Start your diagnosis by looking for "conventional" problems first. This is one of the best ways to troubleshoot brake problems on an ABS controlled vehicle. Also check related Service bulletins for information.

# TROUBLE DIAGNOSES

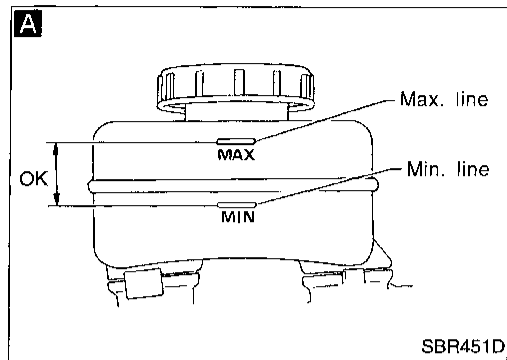

SBR451D

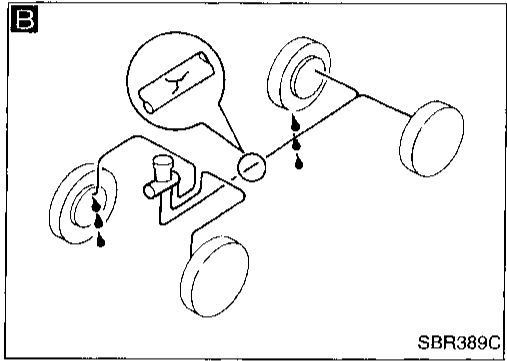

SBR389C

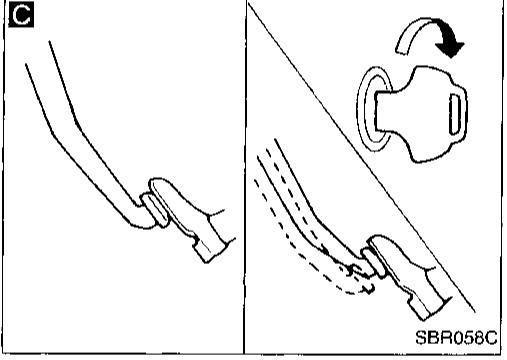

SBR058C

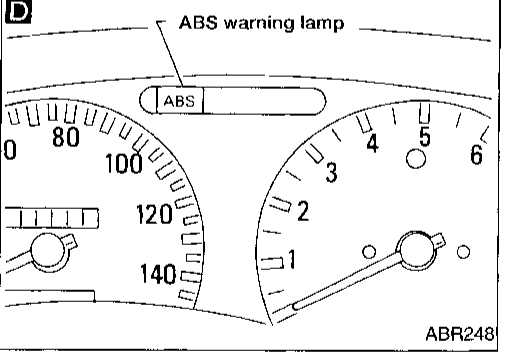

ABR248

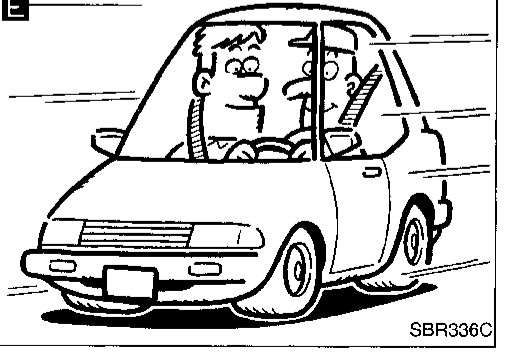

SBR336C

## Preliminary Check

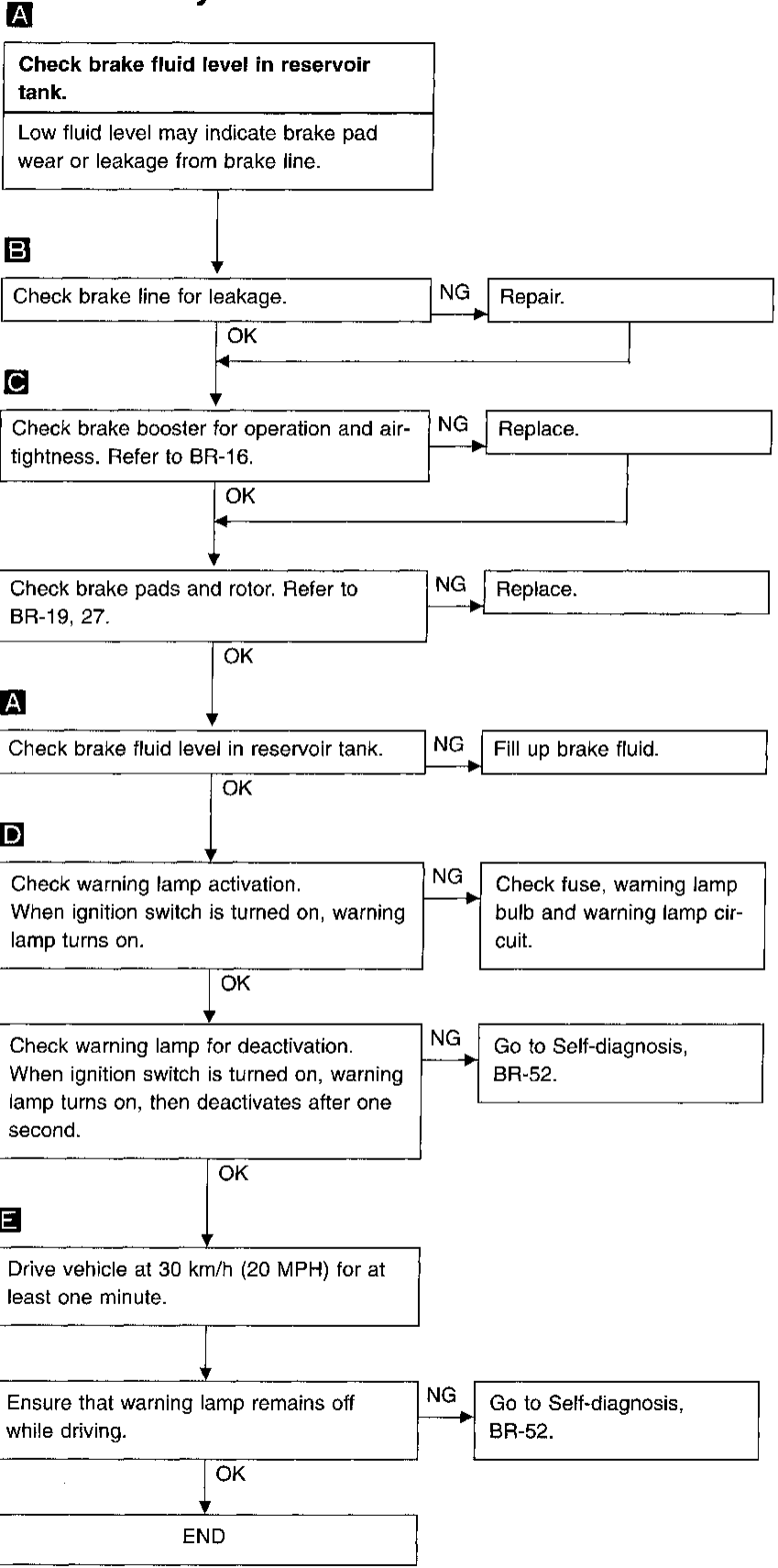

GI  
MA  
EM  
LC  
EC  
FE  
CL  
MT  
AT  
FA  
RA  
**BR**  
ST  
RS  
BT  
HA  
EL  
IDX

# TROUBLE DIAGNOSES

## Component Parts and Harness Connector Location

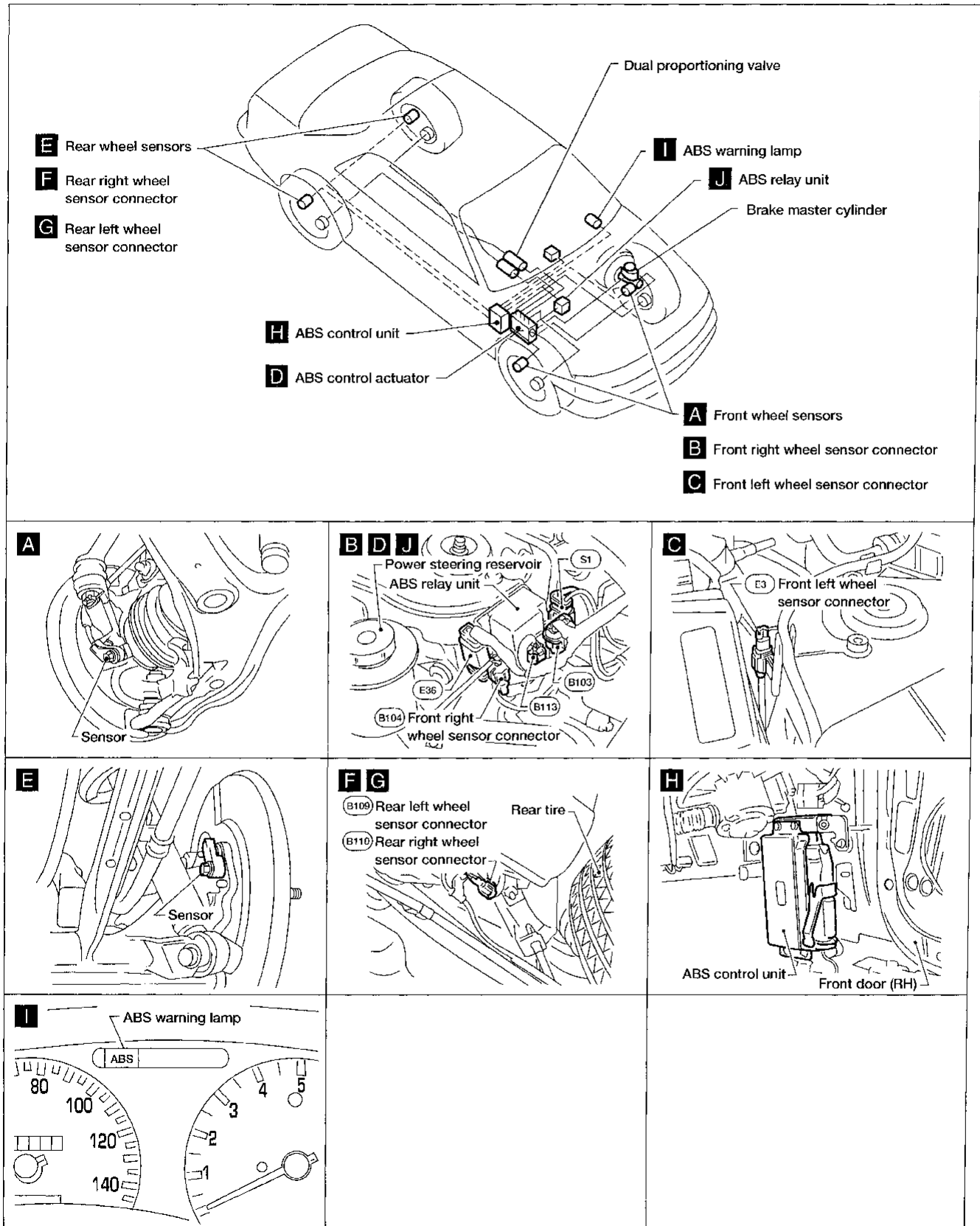

ABR619

# TROUBLE DIAGNOSES

## Schematic

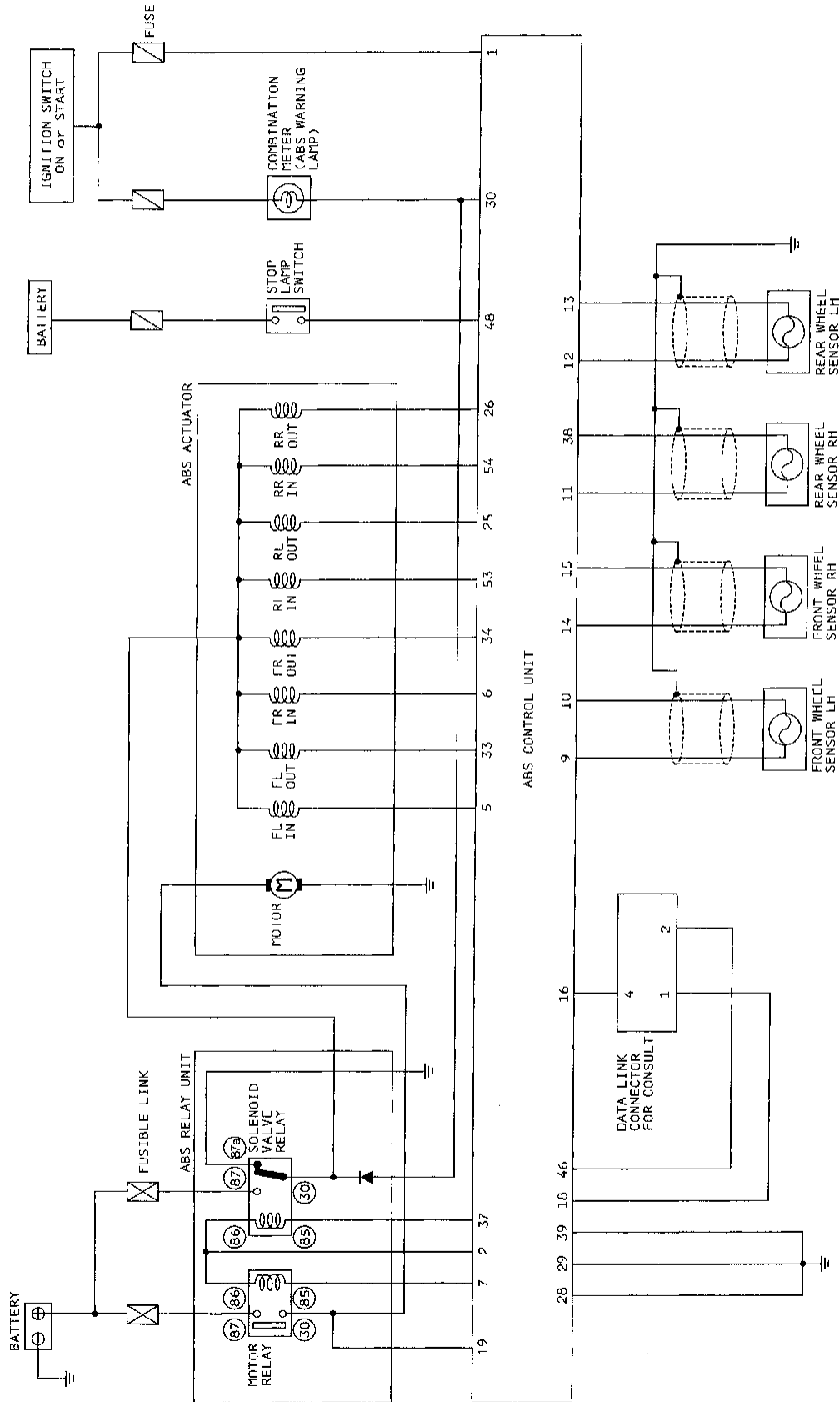

- GI
- MA
- EM
- LC
- EC
- FE
- CL
- MT
- AT
- FA
- RA
- BR**
- ST
- RS
- BT
- HA
- EL
- IDX

Wiring Diagram -ABS-

BR-ABS-01

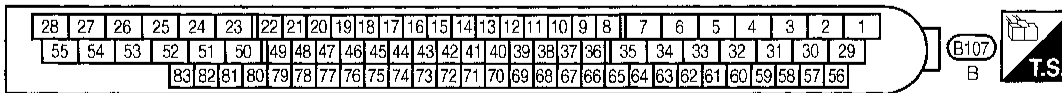
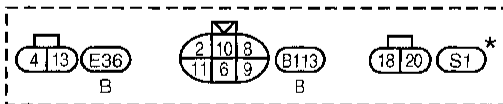
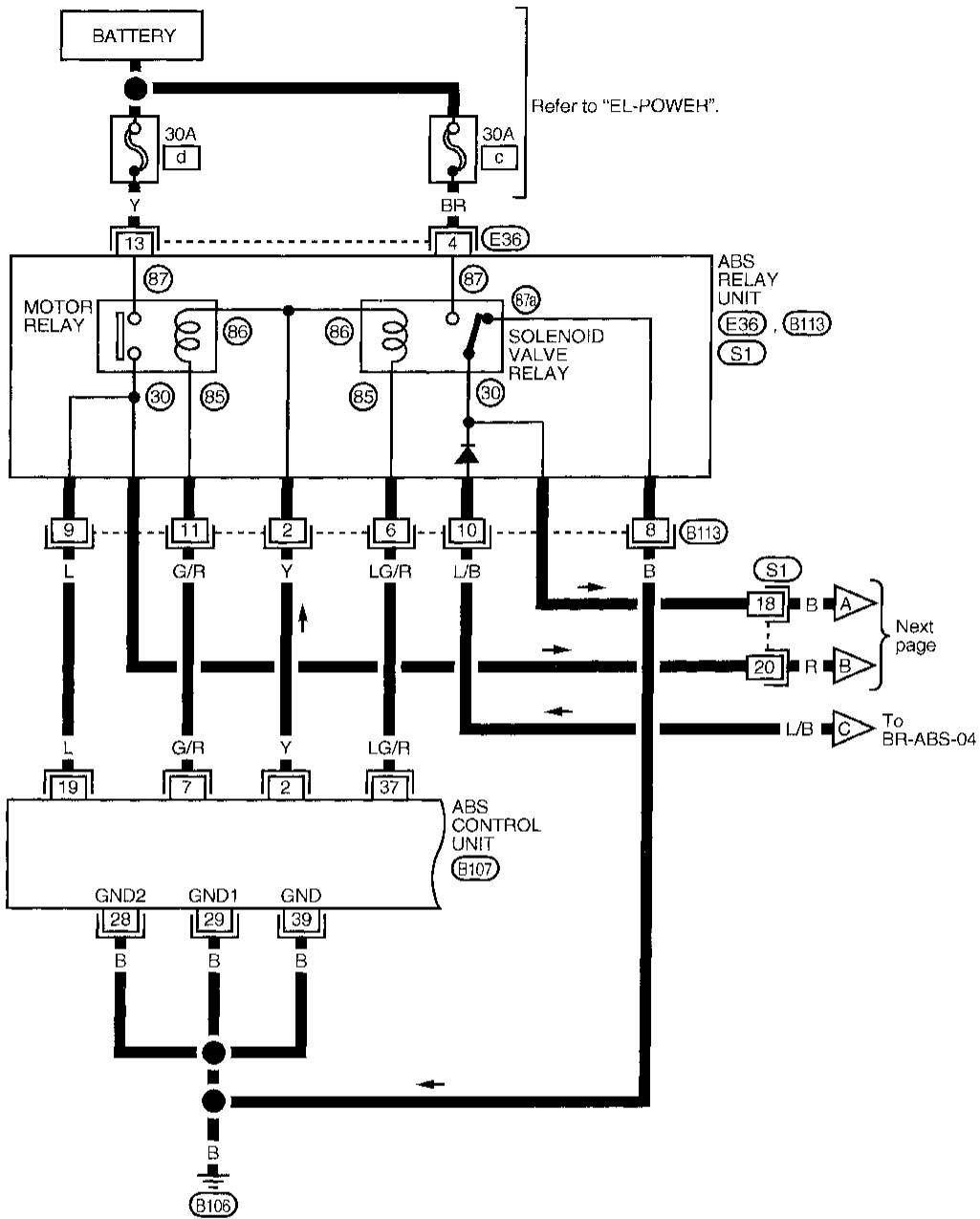

\*: This connector is not shown in "HARNES LAYOUT" of EL section.



# TROUBLE DIAGNOSES

## Wiring Diagram -ABS- (Cont'd)

BR-ABS-02

CI  
MA  
EM  
LC  
EC  
FE  
CL  
MT  
AT  
FA  
RA  
**BR**  
ST  
RS  
BT  
HA  
EL  
IDX

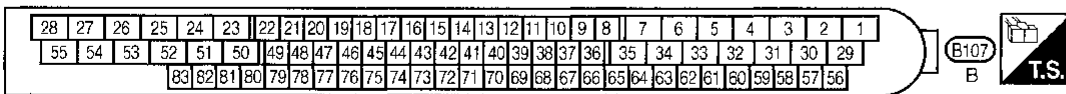
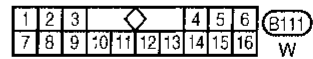
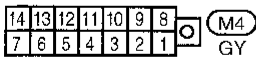
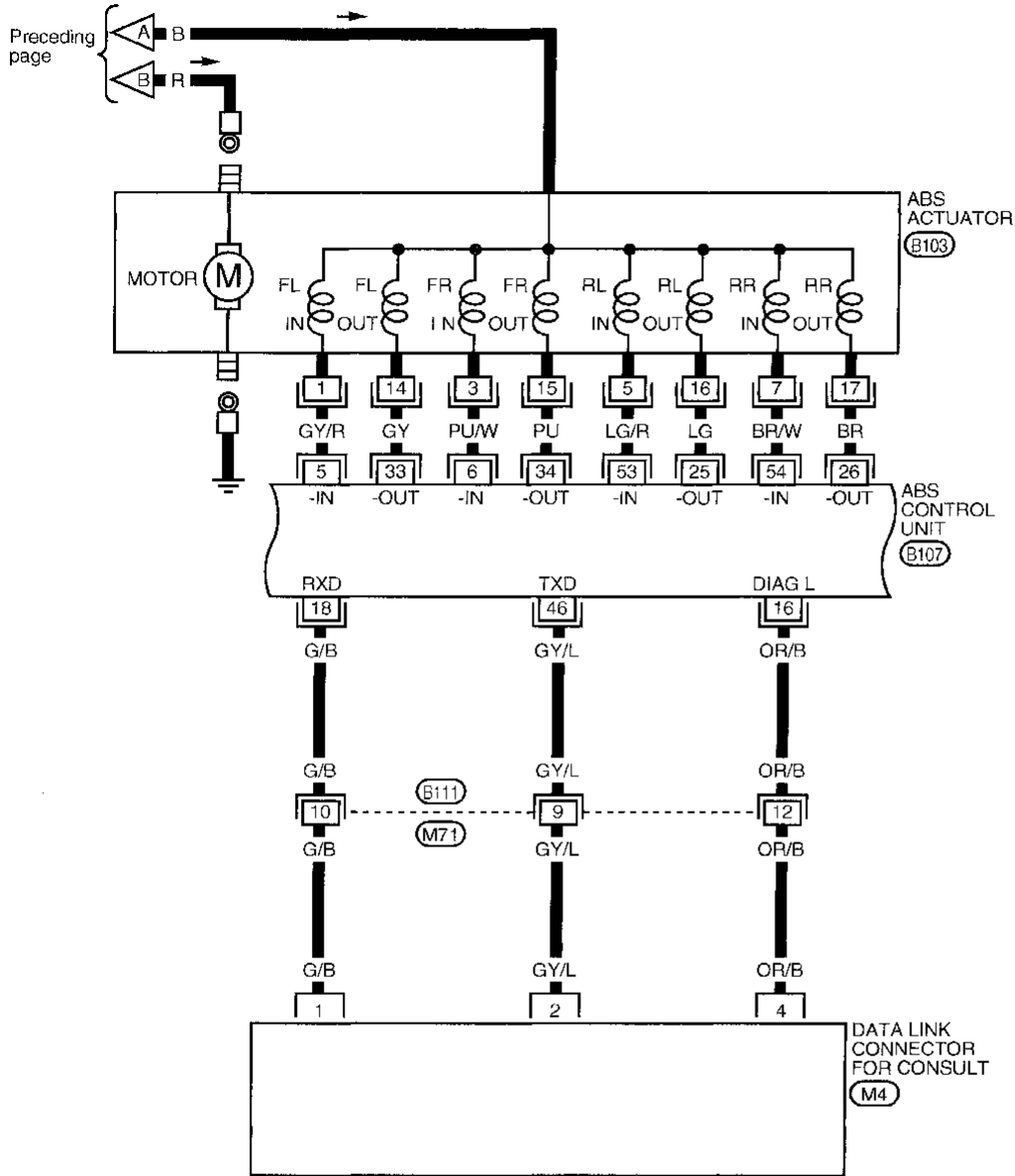

# TROUBLE DIAGNOSES

## Wiring Diagram - ABS- (Cont'd)

BR-ABS-03

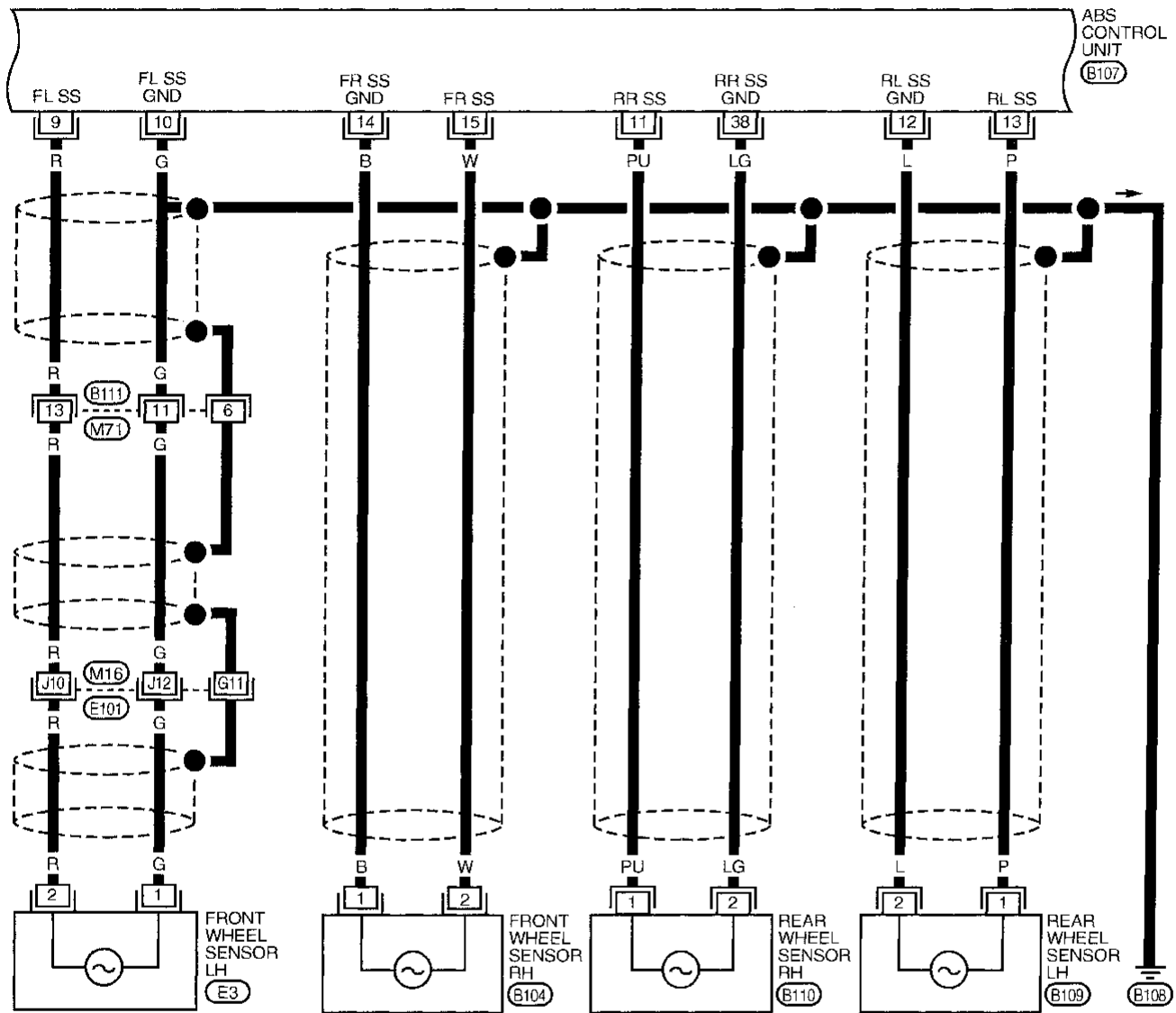

Refer to last page (Foldout page).

(M16), (E101)

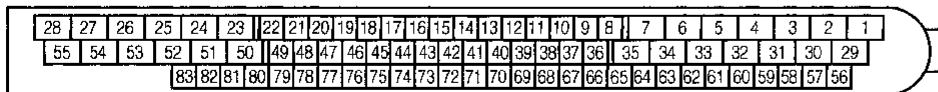

# TROUBLE DIAGNOSES

## Wiring Diagram -ABS- (Cont'd)

BR-ABS-04

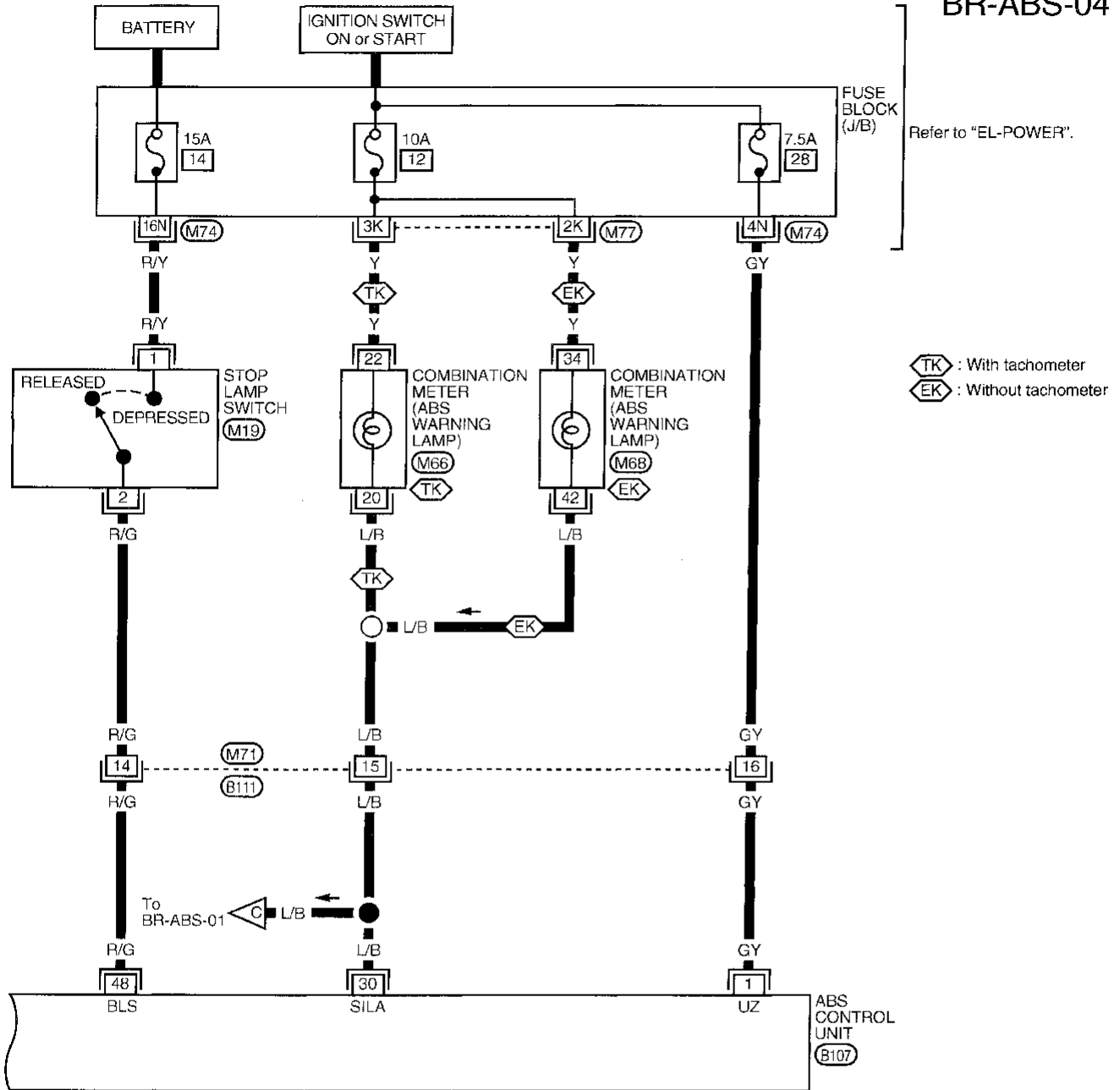

GI  
MA  
EM  
LC  
EC  
FE  
CL  
MT  
AT  
FA  
RA  
**BR**  
ST  
RS  
BT  
HA  
EL  
IDX

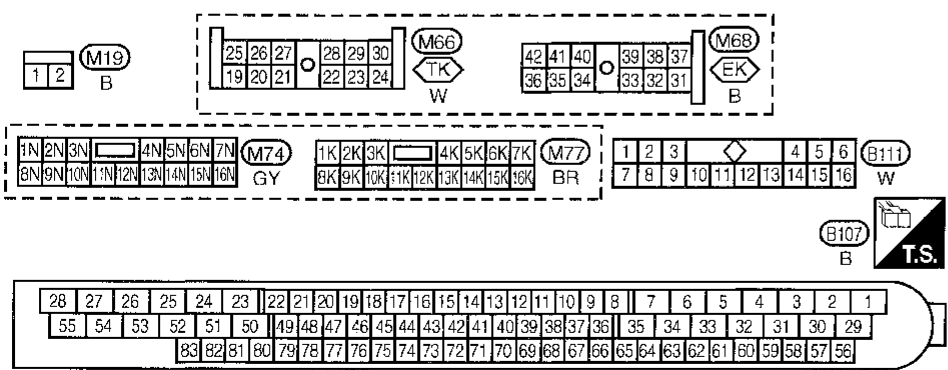

## Self-diagnosis

### FUNCTION

- When a problem occurs in the ABS, the warning lamp on the instrument panel comes on. To start the self-diagnostic results mode, ground the self-diagnostic (check) terminal located on "Data Link Connector for CONSULT". The cause of the malfunction code is indicated by the warning lamp flashing on the instrument panel.

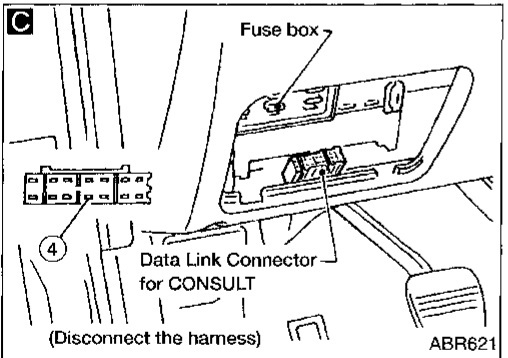
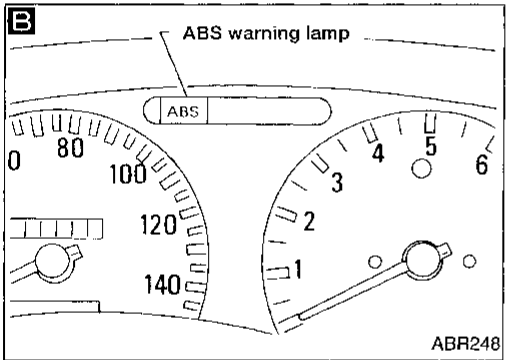
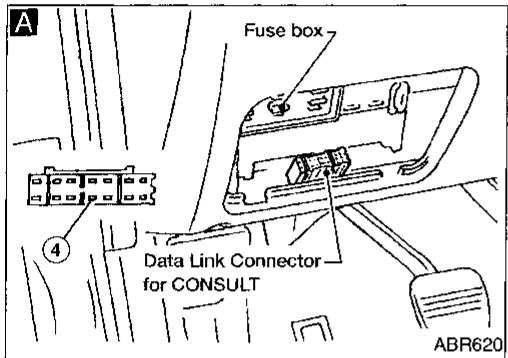

### SELF-DIAGNOSIS PROCEDURE

Drive vehicle over 30 km/h (20 MPH) for at least one minute.

Turn ignition switch OFF.

**A** Ground terminal "4" of Data Link Connector for CONSULT with a suitable harness.

Turn ignition switch ON while grounding terminal "4".  
**Do not depress brake pedal.**

**B** After 3.0 seconds, the warning lamp starts flashing to indicate the malfunction code No. (See NOTE.)

Verify the location of the malfunction with the malfunction code chart. Refer to BR-54. Then make the necessary repairs following the diagnostic procedures.

After the malfunctions are repaired, erase the malfunction codes stored in the control unit. Refer to BR-53.

Rerun the self-diagnostic results mode to verify that the malfunction codes have been erased.

**C** Disconnect the check terminal from the ground. The self-diagnostic results mode is now complete.

**NOTE:** The indication terminates after five minutes. However, when the ignition switch is turned from OFF to ON, the indication starts flashing again.

**A**

# TROUBLE DIAGNOSES

## Self-diagnosis (Cont'd)

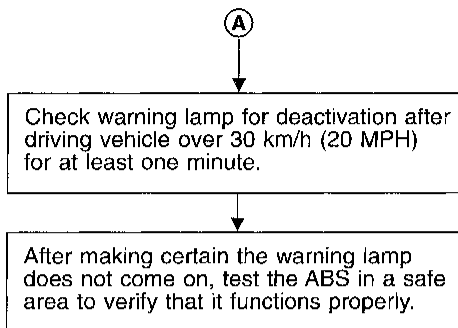

### HOW TO READ SELF-DIAGNOSTIC RESULTS (Malfunction codes)

- Determine the code No. by counting the number of times the warning lamp flashes on and off.
- When several malfunctions occur at one time, up to three code numbers can be stored; the latest malfunction will be indicated first.
- The indication begins with the start code 12. After that a maximum of three code numbers appear in the order of the latest one first. The indication then returns to the start code 12 to repeat (the indication will stay on for five minutes at the most).
- The malfunction code chart is given on the next page.

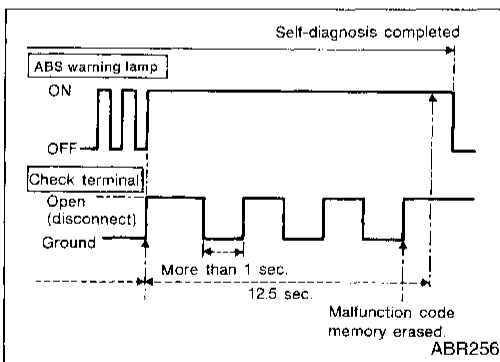
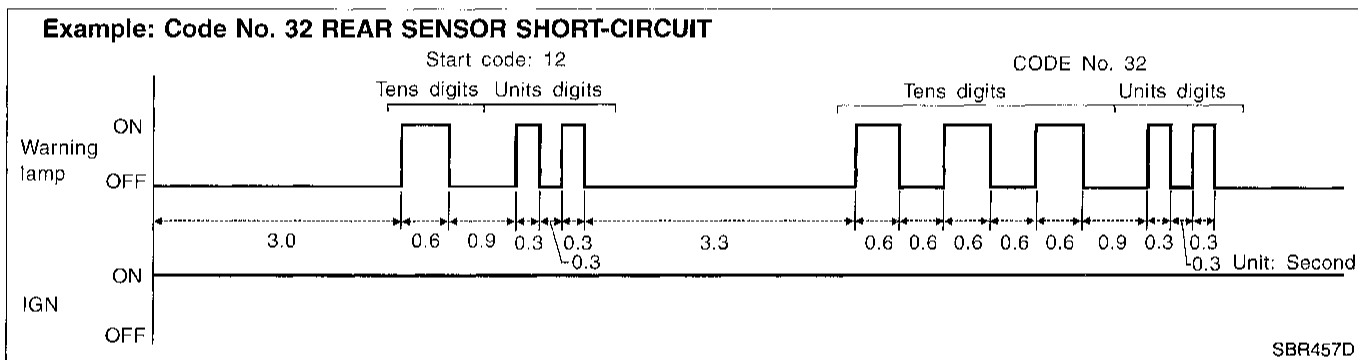

### HOW TO ERASE SELF-DIAGNOSTIC RESULTS (Malfunction codes)

- Under the self-diagnostic results mode, the malfunction memory erase mode starts when the check terminal is disconnected from the ground.
- The self-diagnostic results (malfunction codes) can be erased by grounding the check terminal more than three times in succession within 12.5 seconds after the erase mode starts. (Each grounding must be longer than one second.)  
The ABS warning lamp stays on while the self-diagnosis is in the erase mode, and goes out after the erase operation has been completed.
- The self-diagnosis is also completed at the same time. (Refer to BR-52.)

**After the erase operation is completed, it is necessary to rerun the self-diagnostic mode to verify that malfunction codes no longer appear. Only the start code (12) should be indicated when erase operation is completed and system is functioning normally.**

## TROUBLE DIAGNOSES

### Self-diagnosis (Cont'd)

#### MALFUNCTION CODE/SYMPPTOM CHART

Code No. (No. of LED flashes)	Malfunctioning part	Diagnostic procedure
12	Self-diagnosis could not detect any malfunctions	—
45	Actuator front left outlet solenoid valve	1
46	Actuator front left inlet solenoid valve	1
41	Actuator front right outlet solenoid valve	1
42	Actuator front right inlet solenoid valve	1
51	Actuator rear right outlet solenoid valve	1
52	Actuator rear right inlet solenoid valve	1
55	Actuator rear left outlet solenoid valve	1
56	Actuator rear left inlet solenoid valve	1
25	Front left sensor (open-circuit)	2
26	Front left sensor (short-circuit)	2
21	Front right sensor (open-circuit)	2
22	Front right sensor (short-circuit)	2
35	Rear left sensor (open-circuit)	2
36	Rear left sensor (short-circuit)	2
31	Rear right sensor (open-circuit)	2
32	Rear right sensor (short-circuit)	2
18	Sensor rotor	2
61	Actuator motor or motor relay	3
63	Solenoid valve relay	4
57	Power supply (low voltage)	5
71	Control unit	6
Warning lamp stays on when ignition switch is turned ON	Control unit power supply circuit Warning lamp bulb circuit Control unit or control unit connector Solenoid valve relay stuck Power supply for solenoid valve relay coil	8
Warning lamp stays on during Self-diagnosis	Control unit	—
Warning lamp does not come on when ignition switch is turned ON	Fuse, warning lamp bulb or warning lamp circuit Control unit	7
Warning lamp does not come on during Self-diagnosis	Control unit	—
Pedal vibration and noise	—	9
Long stopping distance	—	10
Unexpected pedal action	—	11
ABS does not work	—	12
ABS works frequently	—	13

# TROUBLE DIAGNOSES

## CONSULT

### CONSULT APPLICATION TO ABS

ITEM	SELF-DIAGNOSTIC RESULTS	DATA MONITOR	ACTIVE TEST	
Front right wheel sensor	X	X	—	GI
Front left wheel sensor	X	X	—	MA
Rear right wheel sensor	X	X	—	EM
Rear left wheel sensor	X	X	—	
ABS sensor	X	—	—	LC
Stop lamp switch	—	X	—	
Front right inlet solenoid valve	X	X	X	EC
Front right outlet solenoid valve	X	X	X	
Front left inlet solenoid valve	X	X	X	FE
Front left outlet solenoid valve	X	X	X	
Rear right inlet solenoid valve	X	X	X	CL
Rear left inlet solenoid valve	X	X	X	
Rear right outlet solenoid valve	X	X	X	MT
Rear left outlet solenoid valve	X	X	X	
Actuator solenoid valve relay	X	X	—	
Actuator motor relay (ABS MOTOR is shown on the Data Monitor screen.)	X	X	X	AT
ABS warning lamp	—	X	—	FA
Battery voltage	X	X	—	
Control unit	X	—	—	RA

X: Applicable  
—: Not applicable

### ECU (ABS control unit) part number mode

Ignore the ECU part number displayed in the ECU PART NUMBER MODE. Refer to parts catalog to order the ECU.

**BR**

ST

RS

BT

HA

EL

IDX

# TROUBLE DIAGNOSES

## CONSULT Inspection Procedure SELF-DIAGNOSIS PROCEDURE

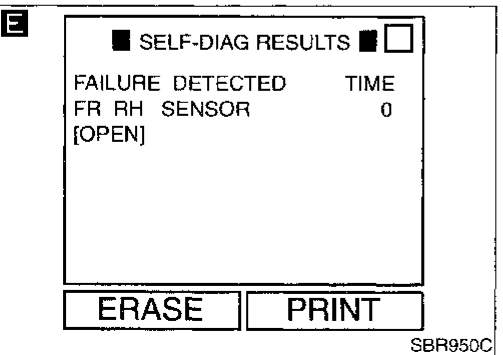
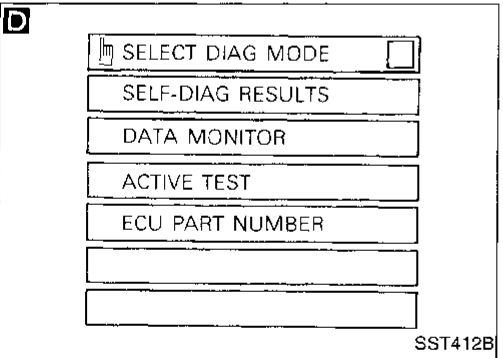
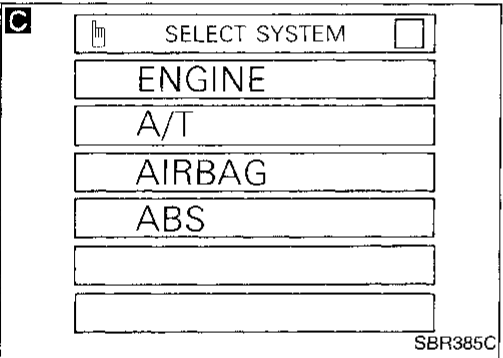
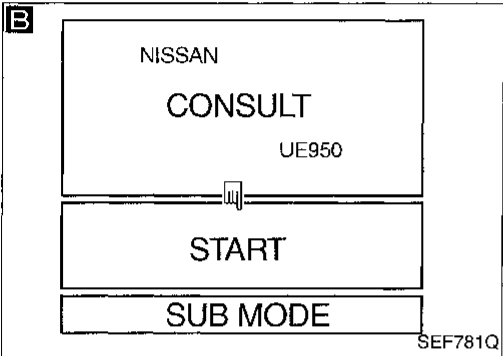
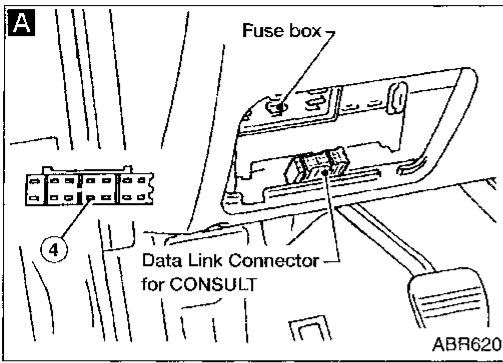

**A**  
1) Turn ignition switch OFF.  
2) Connect CONSULT to Data Link Connector for CONSULT.

1) Start engine.  
2) Drive vehicle over 30 km/h (20 MPH) for at least one minute.

**B** 1) Stop vehicle with engine running and touch "START" on CONSULT screen.  
**C** 2) Touch "ABS".  
**D E** 3) Touch "SELF-DIAG RESULTS".

- The screen shows maximum three malfunctions.
- Does the screen show the detected malfunction?

**WARNING LAMP INSPECTION**  
Check warning lamp and the circuit and repair if necessary.

Yes  
**MALFUNCTION REPAIR**  
Make the necessary repairs following the diagnostic procedures.

**E**  
After repairing the malfunctions, start engine. Then erase the self-diagnostic results stored in the control unit by touching "ERASE".  
**Are the self-diagnostic results erased?**

Yes  
Check warning lamp for deactivation after driving vehicle over 30 km/h (20 MPH) for at least one minute.  
**Does the warning lamp activate?**

Yes  
Go to **E** above.

No  
**End**

**Note:** "SELF-DIAG RESULTS" screen shows the detected malfunction and the times of ignition switch ON and OFF after it occurred.



# TROUBLE DIAGNOSES

## CONSULT Inspection Procedure (Cont'd)

### SELF-DIAGNOSTIC RESULTS MODE

Diagnostic item	Diagnostic item is detected when ...	Diagnostic procedure	
FR RH SENSOR [OPEN]*1	● Circuit for front right wheel sensor is open. (An abnormally high input voltage is entered.)	2	GI
FR LH SENSOR [OPEN]*1	● Circuit for front left wheel sensor is open. (An abnormally high input voltage is entered.)	2	MA
RR RH SENSOR [OPEN]*1	● Circuit for rear right sensor is open. (An abnormally high input voltage is entered.)	2	EM
RR LH SENSOR [OPEN]*1	● Circuit for rear left sensor is open. (An abnormally high input voltage is entered.)	2	LC
FR RH SENSOR [SHORT]*1	● Circuit for front right wheel sensor is shorted. (An abnormally low input voltage is entered.)	2	EC
FR LH SENSOR [SHORT]*1	● Circuit for front left wheel sensor is shorted. (An abnormally low input voltage is entered.)	2	FE
RR RH SENSOR [SHORT]*1	● Circuit for rear right sensor is shorted. (An abnormally low input voltage is entered.)	2	CL
RR LH SENSOR [SHORT]*1	● Circuit for rear left sensor is shorted. (An abnormally low input voltage is entered.)	2	MT
ABS SENSOR [ABNORMAL SIGNAL]	● Teeth damage on sensor rotor or improper installation of wheel sensor. (Abnormal wheel sensor signal is entered.)	2	AT
FR RH IN ABS SOL [OPEN]	● Circuit for front right inlet solenoid valve is open. (An abnormally low output voltage is entered.)	1	FA
FR LH IN ABS SOL [OPEN]	● Circuit for front left inlet solenoid valve is open. (An abnormally low output voltage is entered.)	1	RA
RR RH IN ABS SOL [OPEN]	● Circuit for rear right inlet solenoid valve is open. (An abnormally low output voltage is entered.)	1	BR
RR LH IN ABS SOL [OPEN]	● Circuit for rear left inlet solenoid valve is open. (An abnormally low output voltage is entered.)	1	ST
FR RH IN ABS SOL [SHORT]	● Circuit for front right inlet solenoid valve is shorted. (An abnormally high output voltage is entered.)	1	RS
FR LH IN ABS SOL [SHORT]	● Circuit for front left inlet solenoid valve is shorted. (An abnormally high output voltage is entered.)	1	BT
RR RH IN ABS SOL [SHORT]	● Circuit for rear right inlet solenoid valve is shorted. (An abnormally high output voltage is entered.)	1	HA
RR LH IN ABS SOL [SHORT]	● Circuit for rear left inlet solenoid valve is shorted. (An abnormally high output voltage is entered.)	1	EL
FR RH OUT ABS SOL [OPEN]	● Circuit for front right outlet solenoid valve is open. (An abnormally low output voltage is entered.)	1	IDX
FR LH OUT ABS SOL [OPEN]	● Circuit for front left outlet solenoid valve is open. (An abnormally low output voltage is entered.)	1	
RR RH OUT ABS SOL [OPEN]	● Circuit for rear right outlet solenoid valve is open. (An abnormally low output voltage is entered.)	1	
RR LH OUT ABS SOL [OPEN]	● Circuit for rear left outlet solenoid valve is open. (An abnormally low output voltage is entered.)	1	
FR RH OUT ABS SOL [SHORT]	● Circuit for front right outlet solenoid valve is shorted. (An abnormally high output voltage is entered.)	1	
FR LH OUT ABS SOL [SHORT]	● Circuit for front left outlet solenoid valve is shorted. (An abnormally high output voltage is entered.)	1	
RR RH OUT ABS SOL [SHORT]	● Circuit for rear right outlet solenoid valve is shorted. (An abnormally high output voltage is entered.)	1	
RR LH OUT ABS SOL [SHORT]	● Circuit for rear left outlet solenoid valve is shorted. (An abnormally high output voltage is entered.)	1	
ABS ACTUATOR RELAY [ABNORMAL]	● Actuator solenoid valve relay is ON, even control unit sends off signal. ● Actuator solenoid valve relay is OFF, even control unit sends on signal.	4	
ABS MOTOR [ABNORMAL]	● Circuit for actuator motor is open or shorted. ● Actuator motor relay is stuck.	3	
BATTERY VOLT [VB-LOW]	● Power source voltage supplied to ABS control unit is abnormally low.	5	
CONTROL UNIT	● Function of calculation in ABS control unit has failed.	6	

\*1: Be sure to confirm the ABS warning lamp illuminates when the ignition switch is turned ON after repairing the shorted sensor circuit, but the lamp goes out when driving the vehicle over 30 km/h (20 MPH) for one minute in accordance with SELF-DIAGNOSIS PROCEDURE.

# TROUBLE DIAGNOSES

## CONSULT Inspection Procedure (Cont'd) DATA MONITOR PROCEDURE

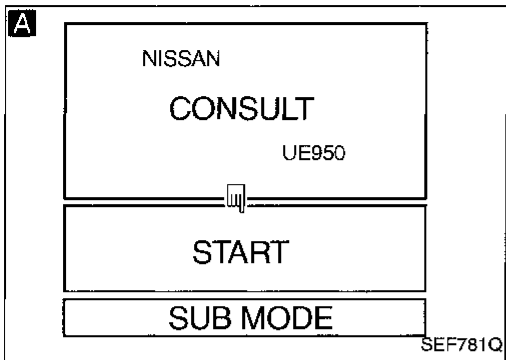

1. Turn ignition switch OFF.
2. Connect CONSULT to Data Link Connector for CONSULT.
3. Turn ignition switch ON.

- A** 1. Touch "START" on CONSULT screen.
- B** 2. Touch "ABS".
- C** 3. Touch "DATA MONITOR".

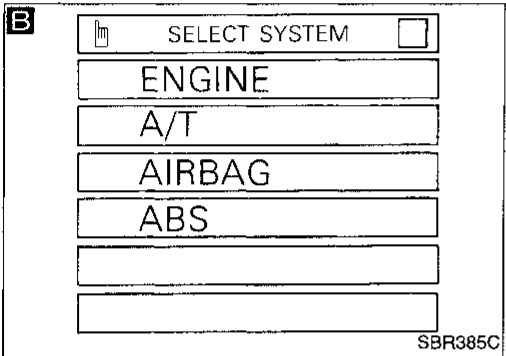

- D** 1. Touch "SETTING" on "SELECT MONITOR ITEM" screen.
- E** 2. Touch "LONG TIME" on "SET RECORDING COND" screen.
- D** 3. Touch "START" on "SELECT MONITOR ITEM" screen.

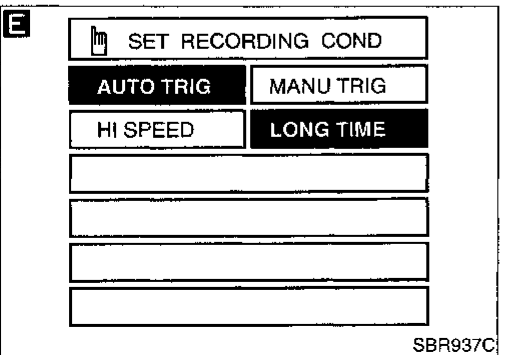
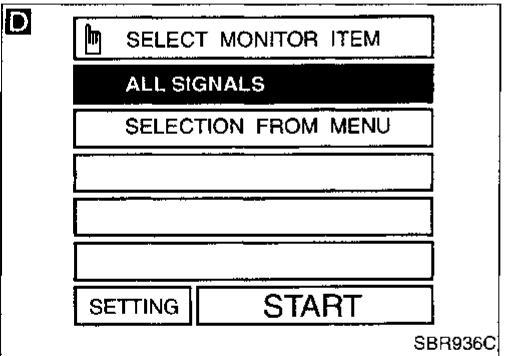
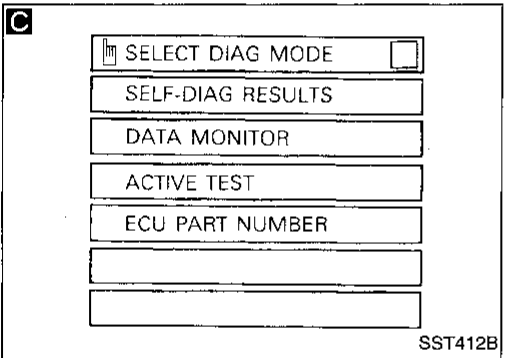

# TROUBLE DIAGNOSES

## CONSULT Inspection Procedure (Cont'd)

### ACTIVE TEST PROCEDURE

- When conducting Active test, vehicle must be stationary.
- When ABS warning lamp stays on, never conduct Active test.

1. Turn ignition switch OFF.
2. Connect CONSULT to Data Link Connector for CONSULT.
3. Start engine.

1. Touch "START" on CONSULT screen.
2. Touch "ABS".
3. Touch "ACTIVE TEST".

1. Select active test item by touching screen.
2. Touch "START".

Carry out the Active test by touching screen key.

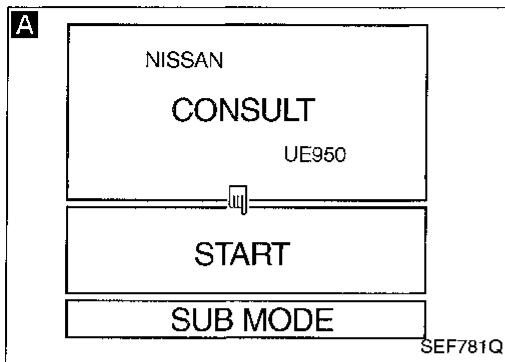

SEF781Q

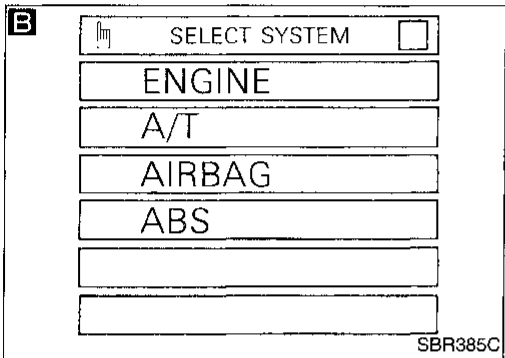

SBR385C

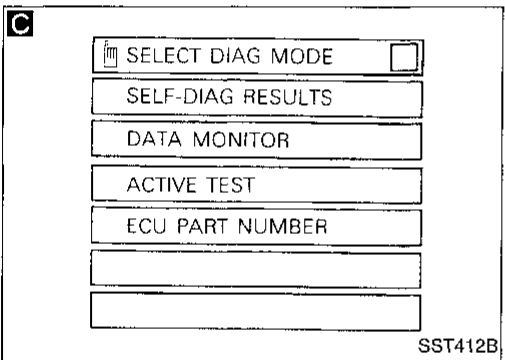

SST412B

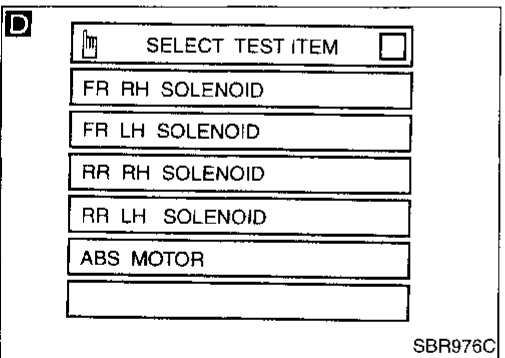

SBR976C

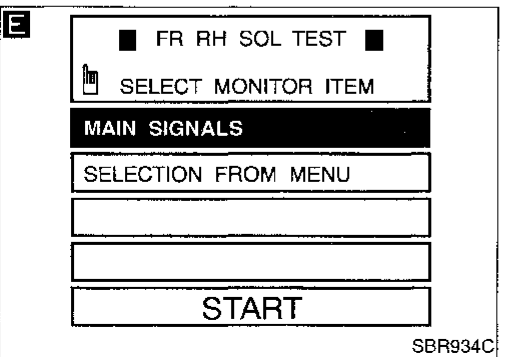

SBR934C

GI

MA

EM

LC

EC

FE

CL

MT

AT

FA

RA

**BR**

ST

RS

BT

HA

EL

IDX

## TROUBLE DIAGNOSES

### CONSULT Inspection Procedure (Cont'd)

#### DATA MONITOR MODE

MONITOR ITEM	CONDITION	SPECIFICATION
FR RH SENSOR FR LH SENSOR RR RH SENSOR RR LH SENSOR	Drive vehicle. (Each wheel is rotating.)	Displays computed vehicle speed from wheel sensor signal. Almost the same speed as speedometer.
STOP LAMP SW	Turn ignition switch ON and depress brake pedal.	Depress the pedal: ON Release the pedal: OFF
FR RH IN SOL FR RH OUT SOL FR LH IN SOL FR LH OUT SOL RR RH IN SOL RR RH OUT SOL RR LH IN SOL RR LH OUT SOL	Ignition switch is turned ON or engine is running.	Operating conditions for each solenoid valve are indicated. ABS is not operating: OFF
ACTUATOR RLY	Ignition switch is turned ON or engine is running.	Displays ON/OFF condition of ABS actuator relay. When turning ignition switch ON, ABS actuator relay is operated.
MOTOR RELAY		ABS is not operating: OFF ABS is operating: ON
WARNING LAMP		Warning lamp is turned on: ON Warning lamp is turned off: OFF
BATTERY VOLT		Power supply voltage for control unit

#### ACTIVE TEST MODE

TEST ITEM	CONDITION	JUDGEMENT												
FR RH SOLENOID FR LH SOLENOID RR RH SOLENOID RR LH SOLENOID	Ignition switch is turned ON.	Brake fluid pressure control operation  <table style="margin-left: 100px;"> <tr> <td></td> <td>IN SOL</td> <td>OUT SOL</td> </tr> <tr> <td>UP (Increase):</td> <td>OFF</td> <td>OFF</td> </tr> <tr> <td>KEEP (Hold):</td> <td>ON</td> <td>OFF</td> </tr> <tr> <td>DOWN (Decrease):</td> <td>ON</td> <td>ON</td> </tr> </table>		IN SOL	OUT SOL	UP (Increase):	OFF	OFF	KEEP (Hold):	ON	OFF	DOWN (Decrease):	ON	ON
		IN SOL	OUT SOL											
UP (Increase):	OFF	OFF												
KEEP (Hold):	ON	OFF												
DOWN (Decrease):	ON	ON												
ABS MOTOR		ABS actuator motor ON: Motor runs OFF: Motor stops												

**Note: Active test will automatically stop ten seconds after the test starts. (TEST IS STOPPED monitor shows ON.)**

# TROUBLE DIAGNOSES

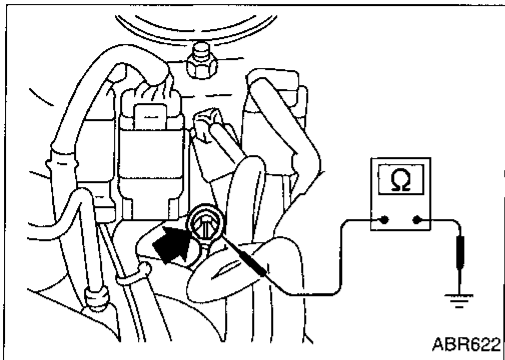

## Ground Circuit Check

### ACTUATOR MOTOR GROUND

- Check resistance between actuator motor ground terminal and body ground.

**Resistance: 0Ω**

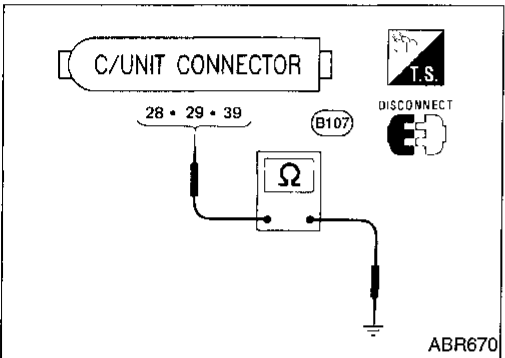

### CONTROL UNIT GROUND

- Check resistance between the terminals and ground.

**Resistance: 0Ω**

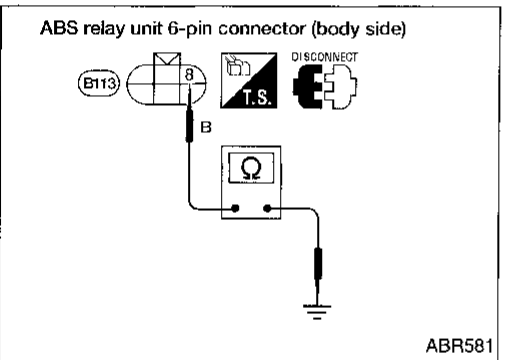

### ABS RELAY UNIT GROUND

- Check resistance between ABS relay unit harness 6-pin connector (body side) terminal ⑧ and ground.

**Resistance: 0Ω**

GI

MA

EM

LC

EC

FE

CL

MT

AT

FA

RA

**BR**

ST

RS

BT

HA

EL

IDX

# TROUBLE DIAGNOSES FOR SELF-DIAGNOSTIC ITEM

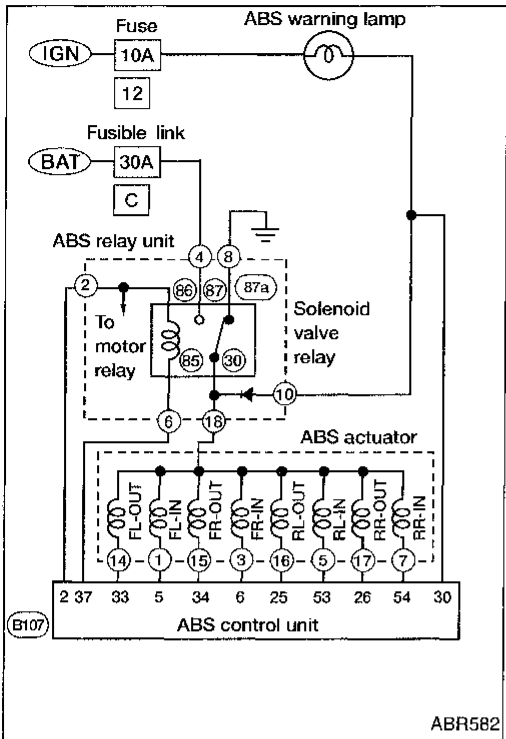

## Diagnostic Procedure 1 (ABS Actuator Solenoid Valve)

Malfunction code No. 41, 45, 51, 55, 42, 46, 52, 56

1. Disconnect connectors from control unit, ABS actuator and ABS relay unit. Check terminals for damage or loose connections. Then reconnect connectors.
2. Carry out Self-diagnosis again.  
**Does warning lamp activate again?**

No → Inspection end.

Yes

### A ABS ACTUATOR SOLENOID VALVE CHECK

1. Disconnect connectors from control unit and ABS relay unit.
2. Check resistance between control unit connector terminals and ABS relay unit 2-pin connector (ABS actuator side) terminal (18).

OK → (A) (Go to next page.)

Code No.	Control unit	ABS actuator	Resistance
41	(34)	(18)	3.4 - 6.9Ω
45	(33)	(18)	
51	(26)	(18)	
55	(25)	(18)	
42	(6)	(18)	6.5 - 13.2Ω
46	(5)	(18)	
52	(54)	(18)	
56	(53)	(18)	

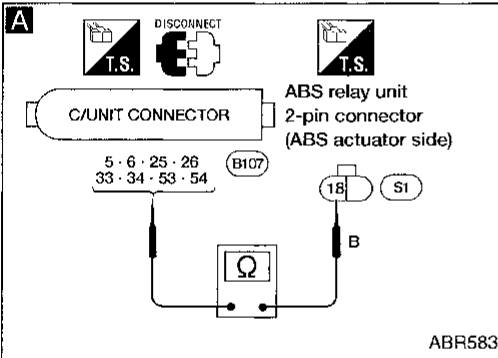

1. Disconnect ABS actuator 8-pin connector.
2. Check resistance between ABS actuator 8-pin connector (ABS actuator side) terminals and ABS relay unit 2-pin connector (ABS actuator side) terminal.

OK → Repair harness and connector between control unit connector terminal and ABS actuator 8-pin connector terminal.

Code No.	ABS actuator	ABS actuator	Resistance
41	(15)	(18)	3.4 - 6.9Ω
45	(14)	(18)	
51	(17)	(18)	
55	(16)	(18)	
42	(3)	(18)	6.5 - 13.2Ω
46	(1)	(18)	
52	(7)	(18)	
56	(5)	(18)	

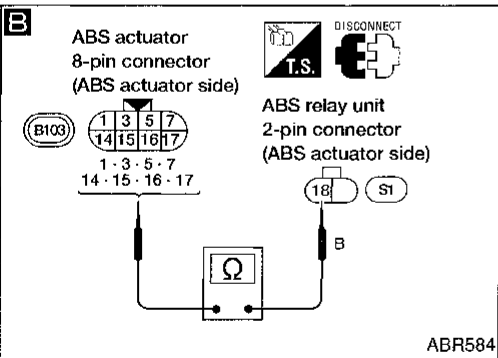

NG

Replace ABS actuator.

# TROUBLE DIAGNOSES FOR SELF-DIAGNOSTIC ITEM

## Diagnostic Procedure 1 (ABS Actuator Solenoid Valve) (Cont'd)

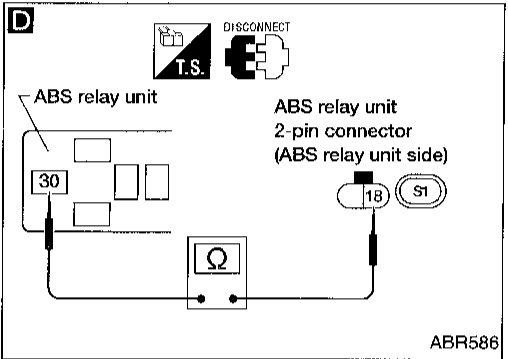
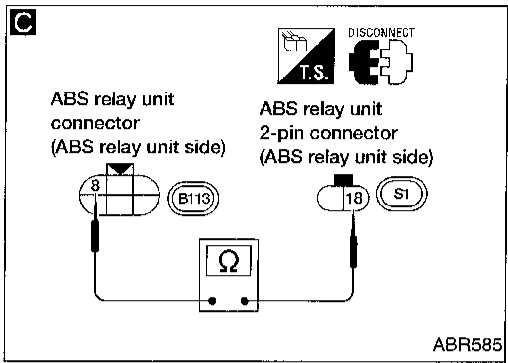

**C**

1. Disconnect ABS relay unit connectors.
2. Check continuity between ABS relay unit 2-pin connector (ABS relay unit side) terminal (18) and ABS relay unit 6-pin connector (ABS relay unit side) terminal (8).

**Continuity should exist.**

OK → Go to Diagnostic Procedure 7, BR-73.

**D**

1. Remove solenoid valve relay.
2. Check continuity between ABS relay unit 2-pin connector (ABS relay side) terminal (18) and ABS relay unit terminal (30).

**Continuity should exist.**

NG → Replace ABS relay unit.

OK → Go to Diagnostic Procedure 4, BR-69.

GI  
MA  
EM  
LC  
EC  
FE  
CL  
MT  
AT  
FA  
RA  
**BR**  
ST  
RS  
BT  
HA  
EL  
IDX

# TROUBLE DIAGNOSES FOR SELF-DIAGNOSTIC ITEM

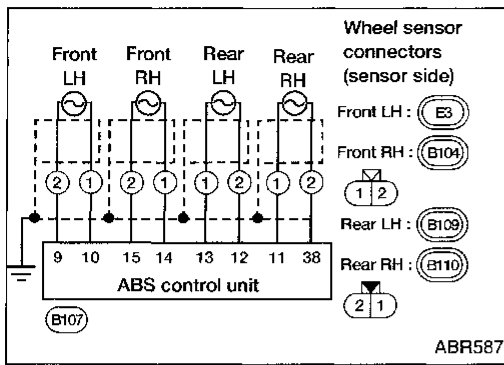

## Diagnostic Procedure 2 (Wheel Sensor or Rotor)

**Malfunction code No. 21, 22, 25, 26, 31, 32, 35, 36 or 18**

1. Disconnect connectors from control unit and wheel sensor of malfunction code No. Check terminals for damage or loose connections. Then reconnect connectors.
  2. Carry out Self-diagnosis again.
- Does warning lamp activate again?**

No → Inspection end.

Yes

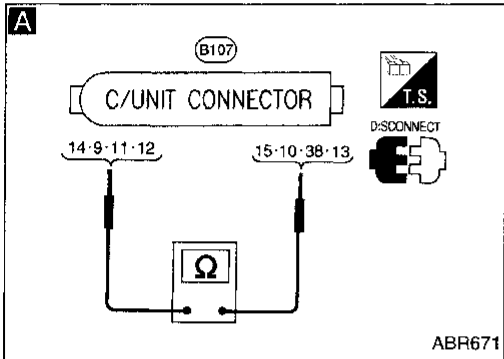

- A**
- WHEEL SENSOR ELECTRICAL CHECK**
1. Disconnect control unit connector.
  2. Check resistance between control unit connector terminals.
- Code No. 21 or 22 (Front RH wheel)  
Terminals 14 and 15
- Code No. 25 or 26 (Front LH wheel)  
Terminals 9 and 10
- Code No. 31 or 32 (Rear RH wheel)  
Terminals 11 and 38
- Code No. 35 or 36 (Rear LH wheel)  
Terminals 12 and 13
- Resistance: 0.6 - 3.25 kΩ**

OK → (Go to next page.)

NG

- Note
- CHECK WHEEL SENSOR**
- Check resistance for each sensor.
- Resistance: 0.6 - 3.25 kΩ**

Note

NG → Replace wheel sensor.

OK

- Note
- Repair harness and connectors between control unit connector and wheel sensor connector.

**Note: Wheel position should be distinguished by code No. except code No. 18 (sensor rotor).**



# TROUBLE DIAGNOSES FOR SELF-DIAGNOSTIC ITEM

## Diagnostic Procedure 2 (Wheel Sensor or Rotor) (Cont'd)

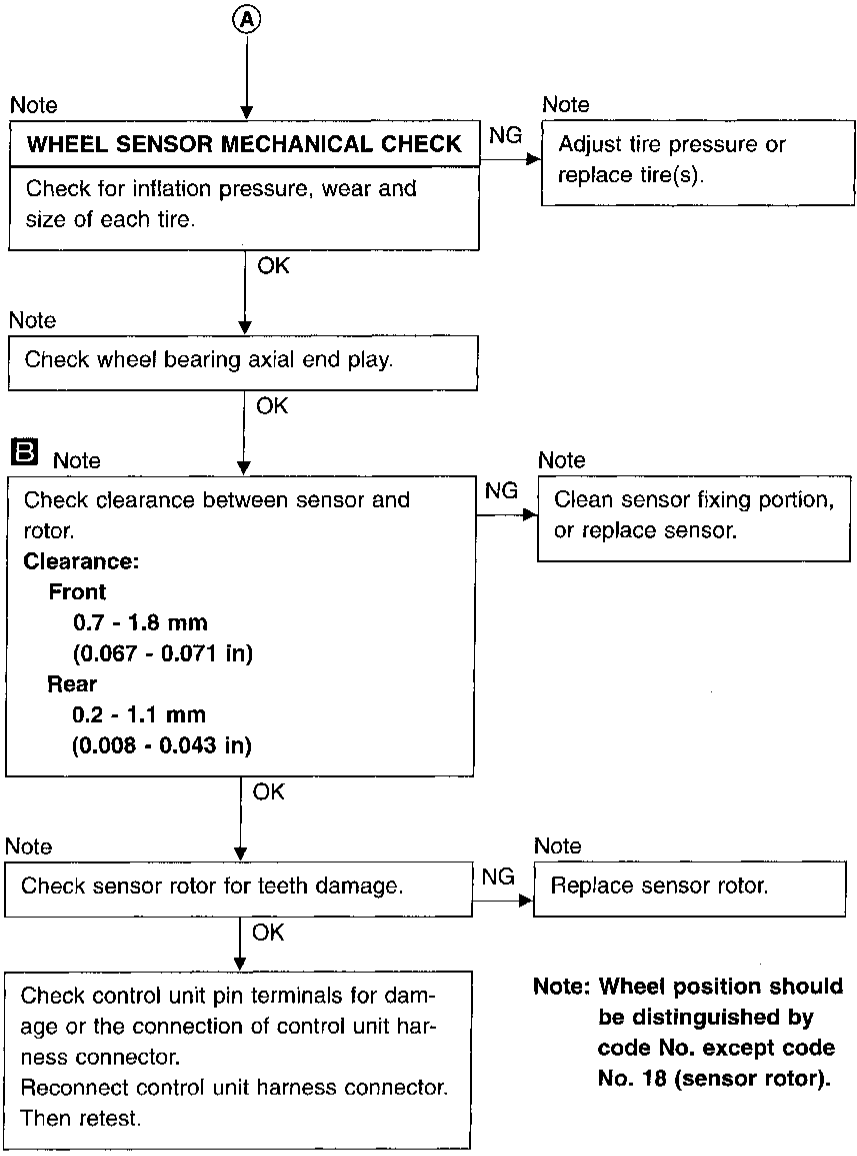
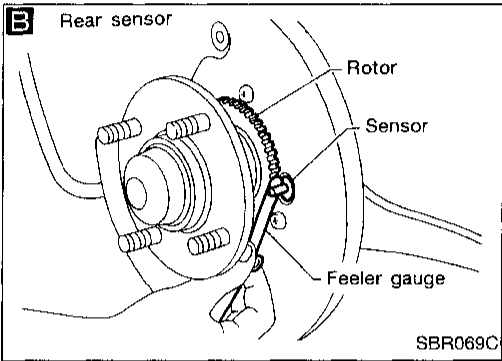
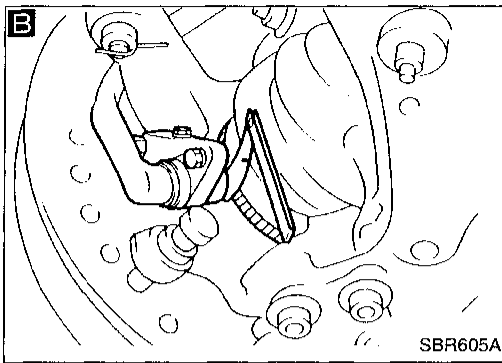

GI  
MA  
EM  
LC  
EC  
FE  
CL  
MT  
AT  
FA  
RA  
BR  
ST  
RS  
BT  
HA  
EL  
IDX

## Diagnostic Procedure 3 (Motor Relay or Motor) Malfunction code No. 61

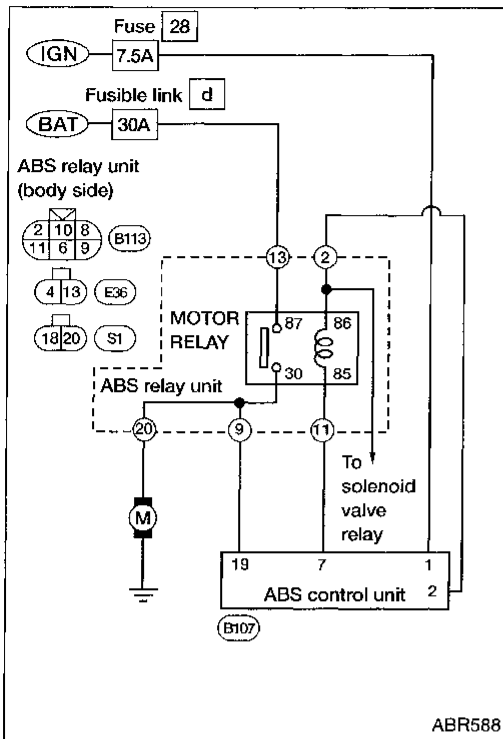

**MOTOR POWER SUPPLY CIRCUIT**

Check fusible link **d** for ABS relay unit. For fusible link layout, refer to ("POWER SUPPLY ROUTING").

NG (Go to **B**) on BR-68.)

OK

1. Disconnect connectors from control unit and ABS actuator. Check terminals for damage or loose connections. Then reconnect connectors.  
2. Carry out Self-diagnosis again.  
**Does warning lamp activate again?**

No Inspection end.

Yes

**A**

1. Disconnect ABS relay unit 2-pin connector.  
2. Check voltage between connector (body side) terminal **13** and ground. **Battery voltage should exist.**

NG Repair harness and connectors.

OK

**B**

**CIRCUIT CHECK**

1. Disconnect ABS relay unit 6-pin connector and control unit connector.  
2. Check continuity between control unit connector terminals and ABS relay unit 6-pin connector (body side) terminals.

Control unit	ABS relay unit
<b>7</b>	<b>11</b>
<b>19</b>	<b>9</b>
<b>2</b>	<b>2</b>

**Continuity should exist.**

NG Repair harness and connectors.

OK

**C**

**MOTOR RELAY CHECK**

Check actuator motor relay applying battery voltage.

Condition	Continuity between <b>30</b> and <b>87</b>
Battery voltage not applied between <b>85</b> and <b>86</b> .	No
Battery voltage applied between <b>85</b> and <b>86</b> .	Yes

**While applying battery voltage to relay terminals, insert fuse into the circuit.**

NG Replace motor relay.

OK

**MOTOR GROUND CHECK**

Refer to "ACTUATOR MOTOR GROUND" in Ground Circuit Check, BR-61.

NG Repair harness and terminals.

OK

**A**  
(Go to next page.)

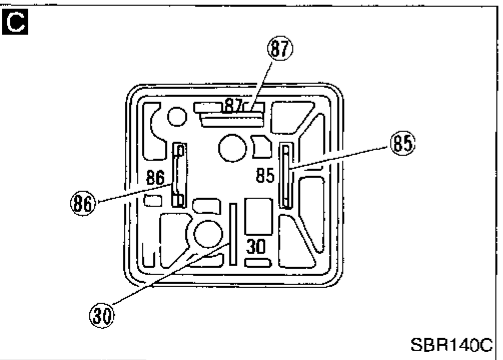
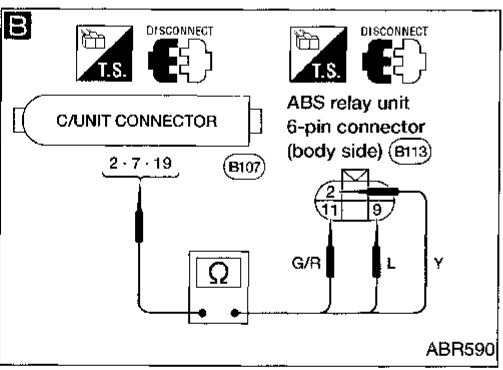
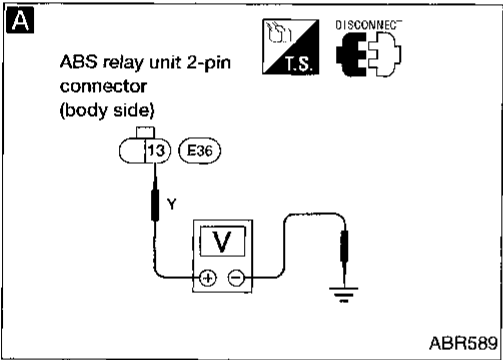

# TROUBLE DIAGNOSES FOR SELF-DIAGNOSTIC ITEM

## Diagnostic Procedure 3 (Motor Relay or Motor) (Cont'd)

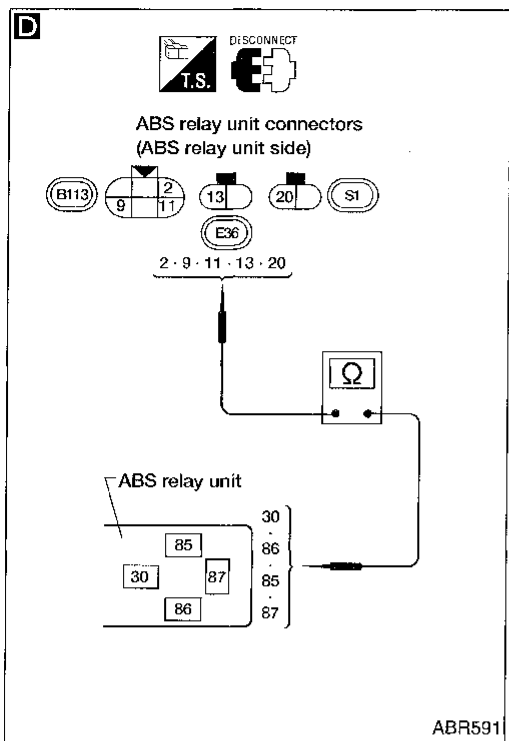

**D**

**MOTOR RELAY CIRCUIT**

1. Remove motor relay.  
2. Check continuity between ABS relay unit connectors (ABS relay unit side) and ABS relay unit terminals.

ABS relay unit connector	ABS relay unit terminal
(2)	(86)
(11)	(85)
(9)	(30)
(13)	(87)
(20)	(30)

Continuity should exist.

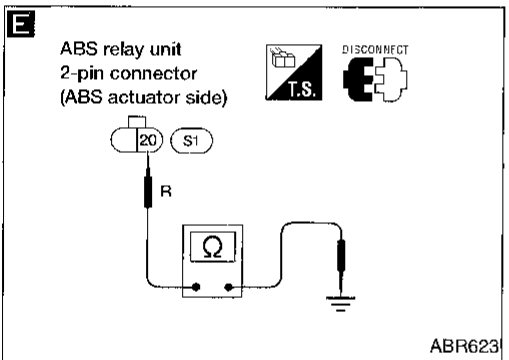

**E**

Check continuity between ABS relay unit 2-pin connector (ABS actuator side) terminal (20) and actuator motor ground terminal.

Continuity should exist.

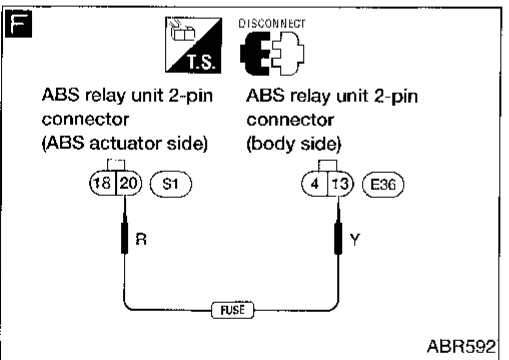

**F**

**MOTOR CHECK**

1. Disconnect ABS relay unit 2-pin connector (E36) and ABS relay unit 2-pin connector (S1).  
2. Connect suitable wire between ABS relay unit 2-pin connector (body side) terminal (13) and ABS relay unit 2-pin connector (ABS actuator side) terminal (20).

Motor should operate.  
Do not connect wire for more than 5 seconds.

Go to Diagnostic Procedure 7, BR-73.

GI  
MA  
EM  
LC  
EC  
FE  
CL  
MT  
AT  
FA  
RA  
BR  
ST  
RS  
BT  
HA  
EL  
IDX

# TROUBLE DIAGNOSES FOR SELF-DIAGNOSTIC ITEM

## Diagnostic Procedure 3 (Motor Relay or Motor) (Cont'd)

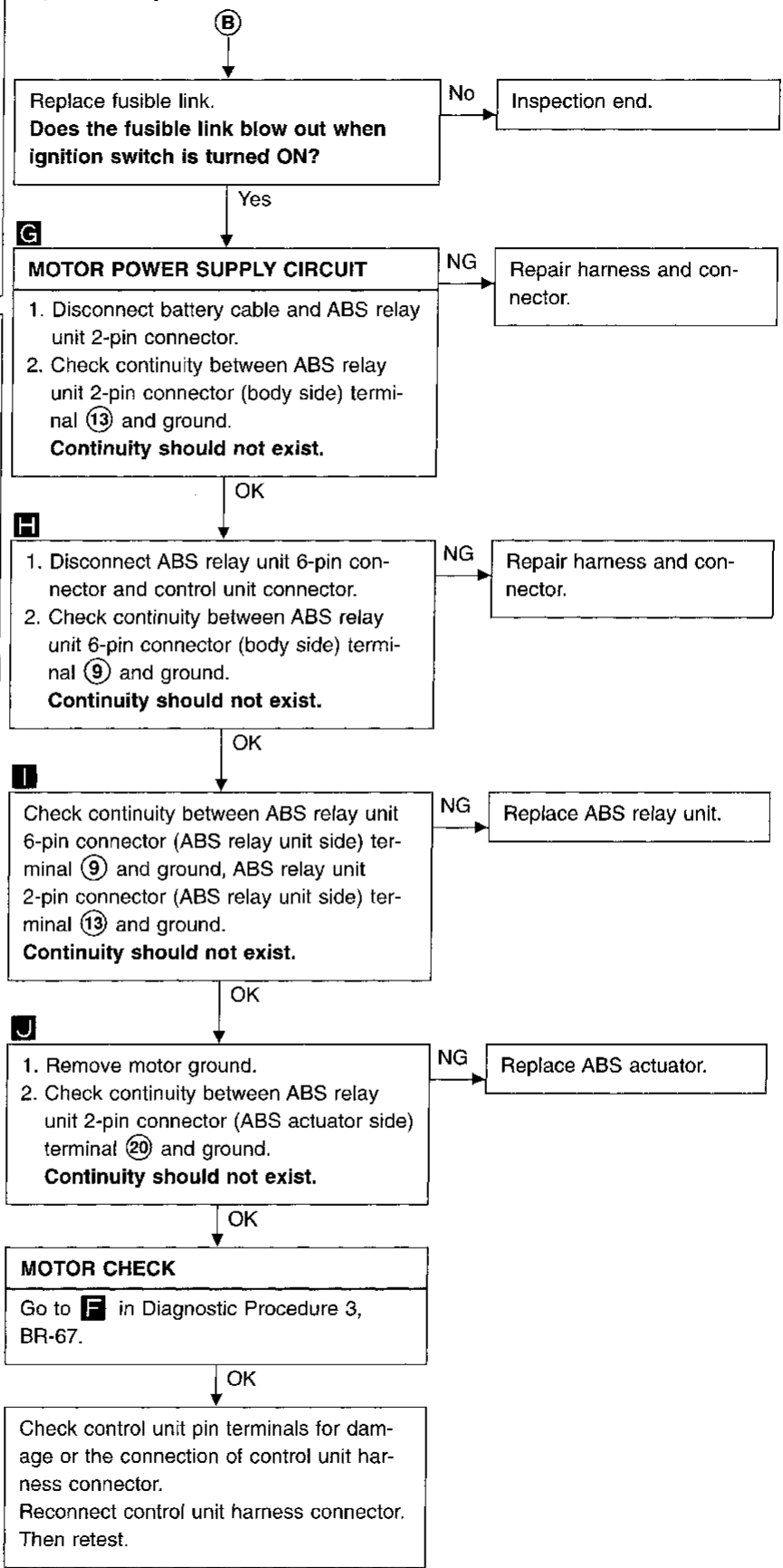
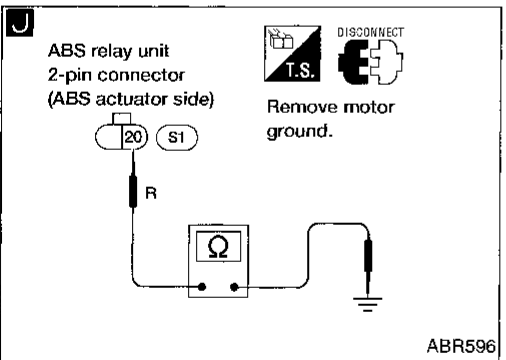
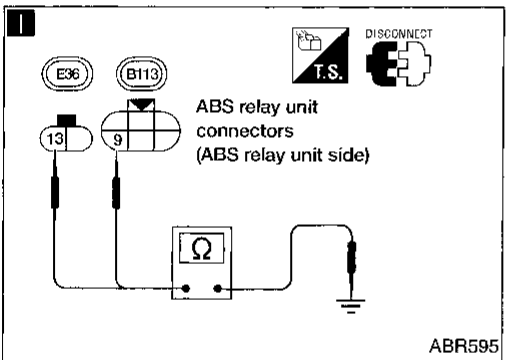
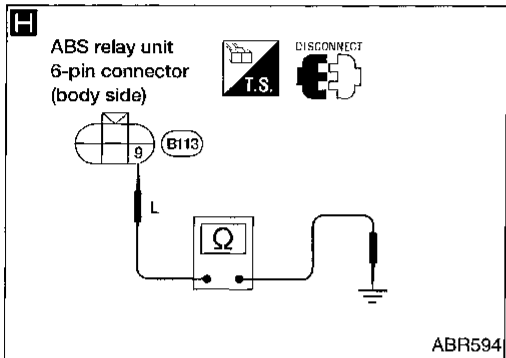
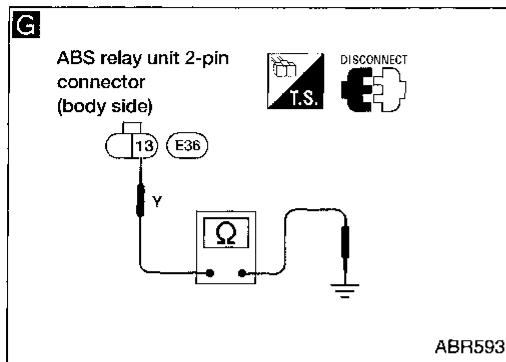

## Diagnostic Procedure 4 (Solenoid Valve Relay)

Malfunction code No. 63

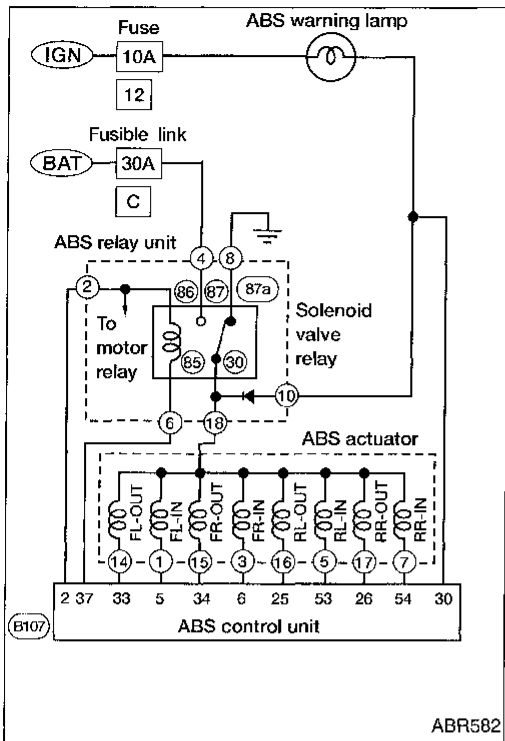

ABR582

**SOLENOID VALVE POWER SUPPLY CHECK**

Check fusible link [C]. For fusible link layout, refer to BR-48.

NG → (A) (See BR-71.)

1. Disconnect connectors from control unit and ABS actuator. Check terminals for damage or loose connections. Then reconnect connectors.

2. Carry out Self-diagnosis again.

**Does warning lamp activate again?**

No → Inspection end.

**GROUND CIRCUIT CHECK**

Refer to "CONTROL UNIT GROUND" and "ACTUATOR MOTOR GROUND" in Ground Circuit Check, BR-61.

NG → Repair harness and connectors.

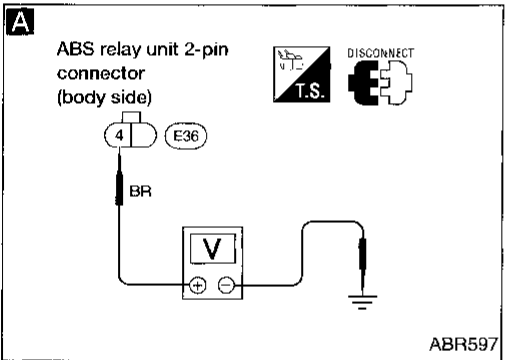

ABR597

**SOLENOID VALVE POWER SUPPLY CHECK**

1. Disconnect connector from ABS relay unit.

2. Check voltage between ABS relay unit 2-pin connector (body side) terminal (4) and ground.

**Battery voltage should exist.**

NG → Repair harness and connector.

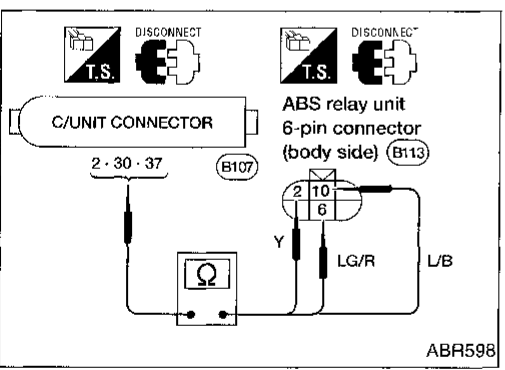

ABR598

**CIRCUIT CHECK**

1. Disconnect control unit connector.

2. Check continuity between control unit connector terminals and ABS relay unit 6-pin connector (body side) terminals.

Control unit	ABS relay unit
(37)	(6)
(2)	(2)
(30)	(10)

NG → Repair harness and connectors.

**Continuity should exist.**

OK → (B) (Go to next page.)

GI  
MA  
EM  
LC  
EC  
FE  
CL  
MT  
AT  
FA  
RA  
BR  
ST  
RS  
BT  
HA  
EL  
IDX

# TROUBLE DIAGNOSES FOR SELF-DIAGNOSTIC ITEM

## Diagnostic Procedure 4 (Solenoid Valve Relay) (Cont'd)

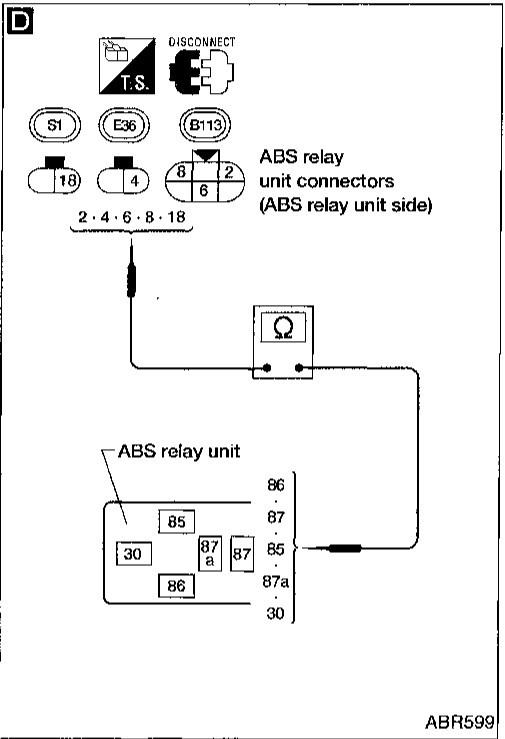
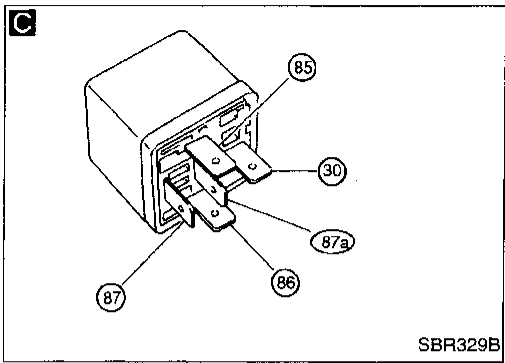

B

**SOLENOID VALVE RELAY CHECK**

Check solenoid valve relay applying battery voltage.

Condition	Continuity	
	between (30) and (87a)	between (30) and (87)
Battery voltage not applied between (85) and (86).	Yes	No
Battery voltage applied between (85) and (86).	No	Yes

**While applying battery voltage to relay terminals, insert fuse into the circuit.**

NG → Replace solenoid valve relay.

OK

**SOLENOID VALVE RELAY CIRCUIT CHECK**

Check continuity between ABS relay terminals and ABS relay unit connector (ABS relay unit side) terminals.

ABS relay unit terminal	ABS relay unit connector
(87)	(4)
(87a)	(8)
(85)	(6)
(86)	(2)
(30)	(18)

**Continuity should exist.**

NG → Replace ABS relay unit.

OK

Go to Diagnostic Procedure 3, BR-66.

# TROUBLE DIAGNOSES FOR SELF-DIAGNOSTIC ITEM

## Diagnostic Procedure 4 (Solenoid Valve Relay) (Cont'd)

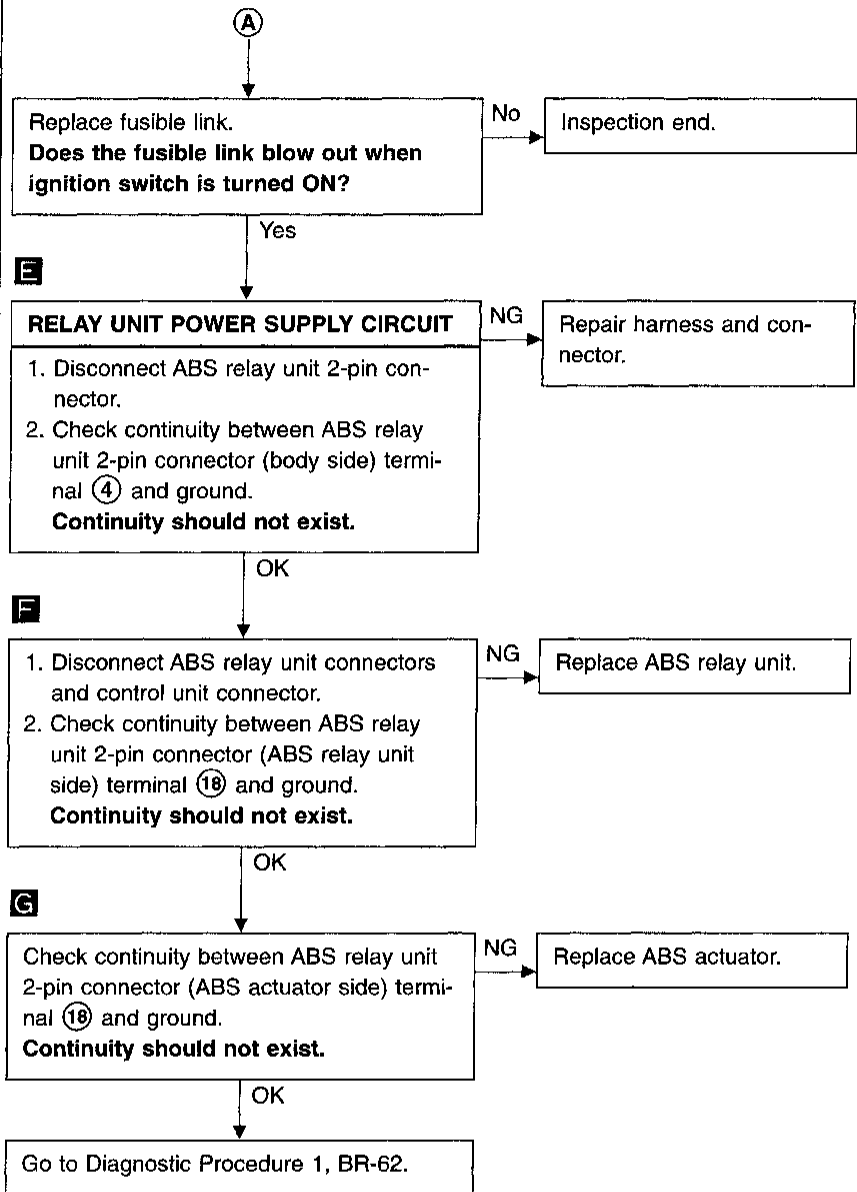
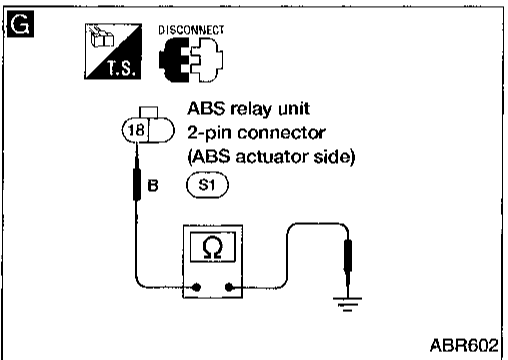
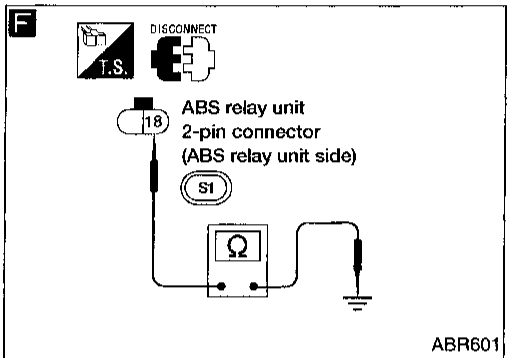
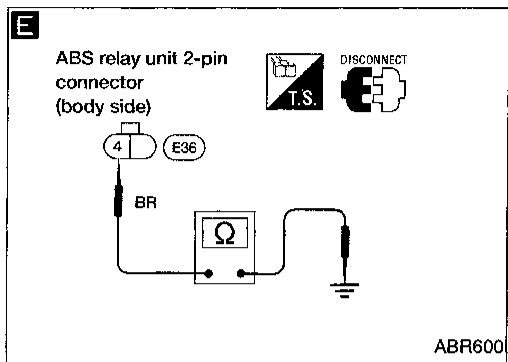

GI  
MA  
EM  
LC  
EC  
FE  
CL  
MT  
AT  
FA  
RA  
BR  
ST  
RS  
BT  
HA  
EL  
IDX

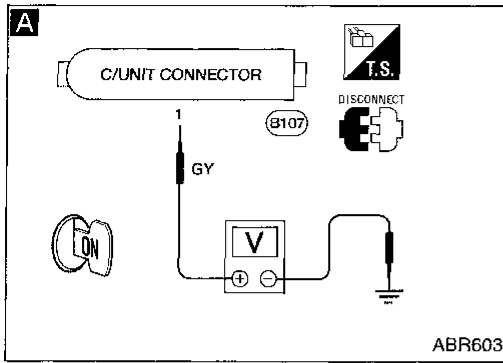

## Diagnostic Procedure 5 (Low Voltage) Malfunction code No. 57

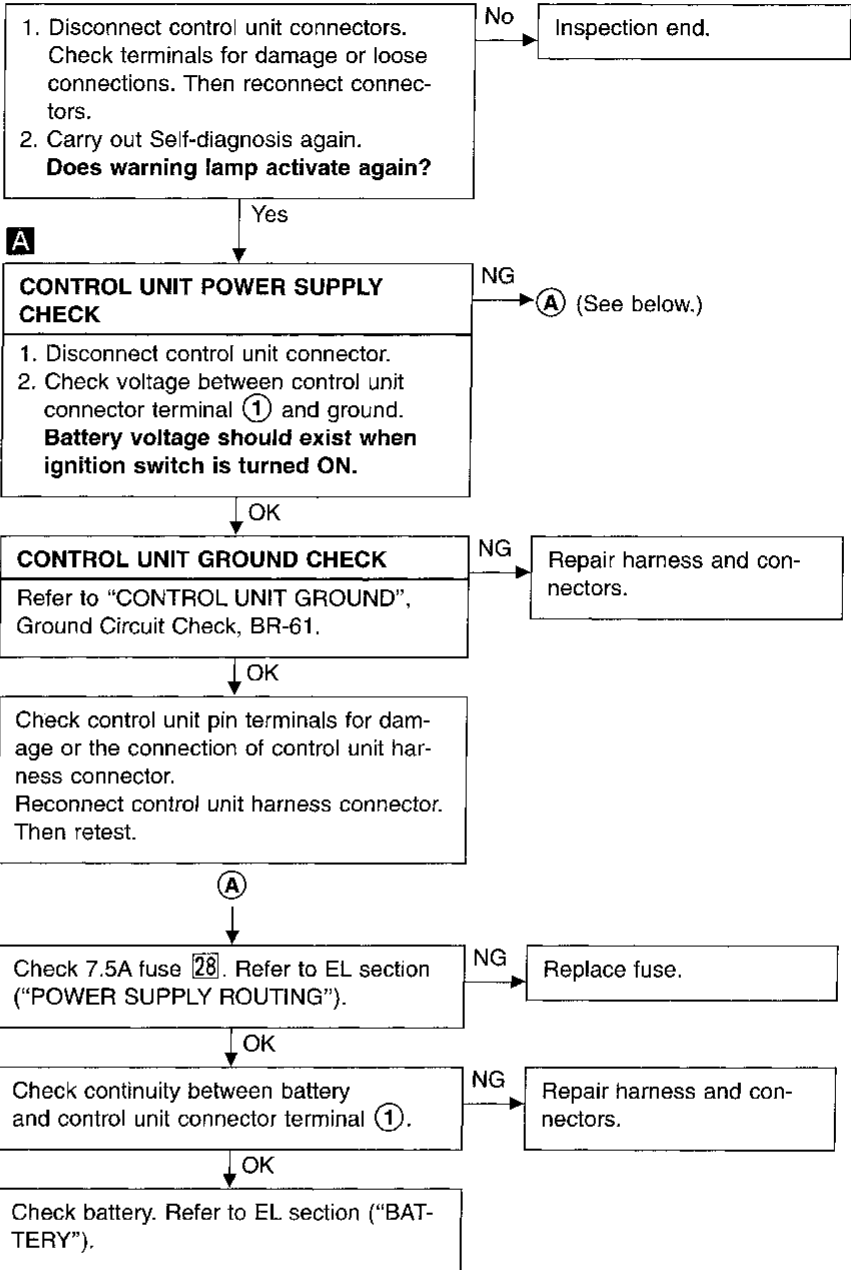

## Diagnostic Procedure 6 (Control Unit) Malfunction code No. 71

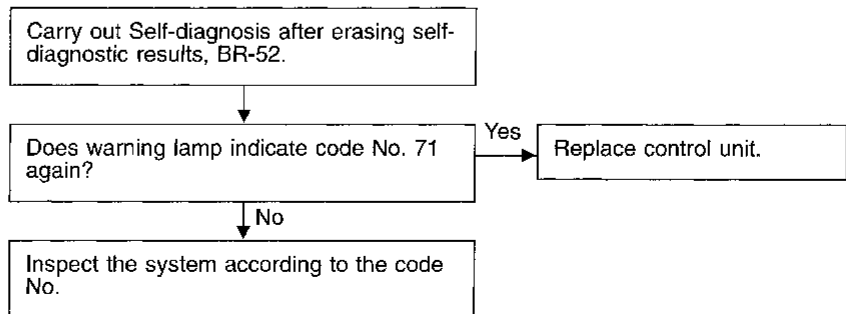



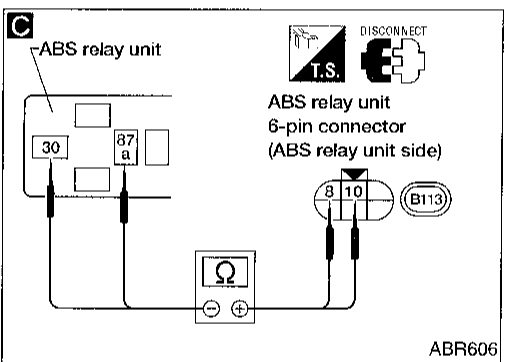
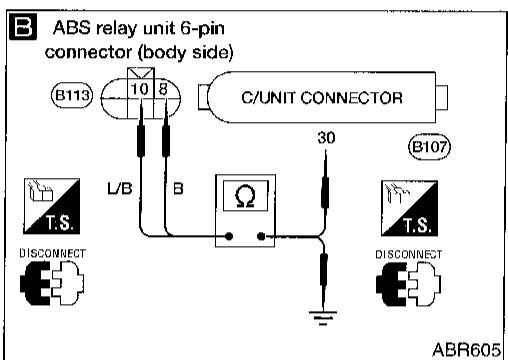
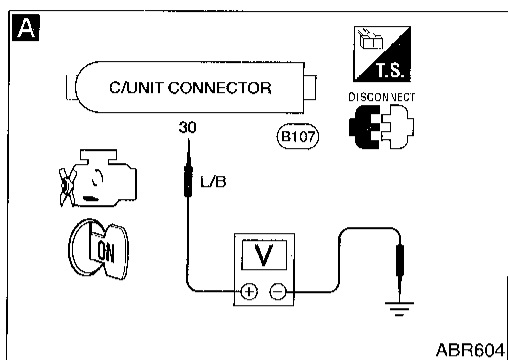

## Diagnostic Procedure 7 (Warning Lamp Does Not Come On)

Warning lamp does not come on when ignition switch is turned ON.

**WARNING LAMP CIRCUIT CHECK**

Check 10A fuse 12 for warning lamp. For fuse layout, refer to BR-51.

NG → Replace fuse.

OK ↓

Check warning lamp bulb.

NG → Replace bulb.

OK ↓

**A**

1. Install 10A fuse and bulb.
2. Disconnect connectors from control unit and ABS relay unit.
3. Check voltage between control unit connector terminal 30 and ground after turning ignition switch ON.

Battery voltage should exist after turning ignition switch ON.

NG → Repair harness and connectors.

OK ↓

**B**

Check continuity between ABS relay unit 6-pin connector (body side) and control unit terminal.

ABS relay unit	Control unit
10	30
8	Ground

Continuity should exist.

NG → Repair harness and connectors.

OK ↓

**C**

1. Remove solenoid valve relay.
2. Check continuity between ABS relay unit 6-pin connector (ABS relay unit side) and ABS relay unit terminals.

ABS relay unit connector	ABS relay unit terminals
10 ⊕	30 ⊖
8	37a

Continuity should exist.

Note: Specifications may vary depending on tester type. Before performing this inspection, be sure to refer to the instruction manual for tester being used.

NG → Replace ABS relay unit.

OK ↓

(Go to next page.)

GI  
 MA  
 EM  
 LC  
 EC  
 FE  
 CL  
 MT  
 AT  
 FA  
 RA  
**BR**  
 ST  
 RS  
 BT  
 HA  
 EL  
 IDX

# TROUBLE DIAGNOSES FOR SYMPTOM

## Diagnostic Procedure 7 (Warning Lamp Does Not Come On) (Cont'd)

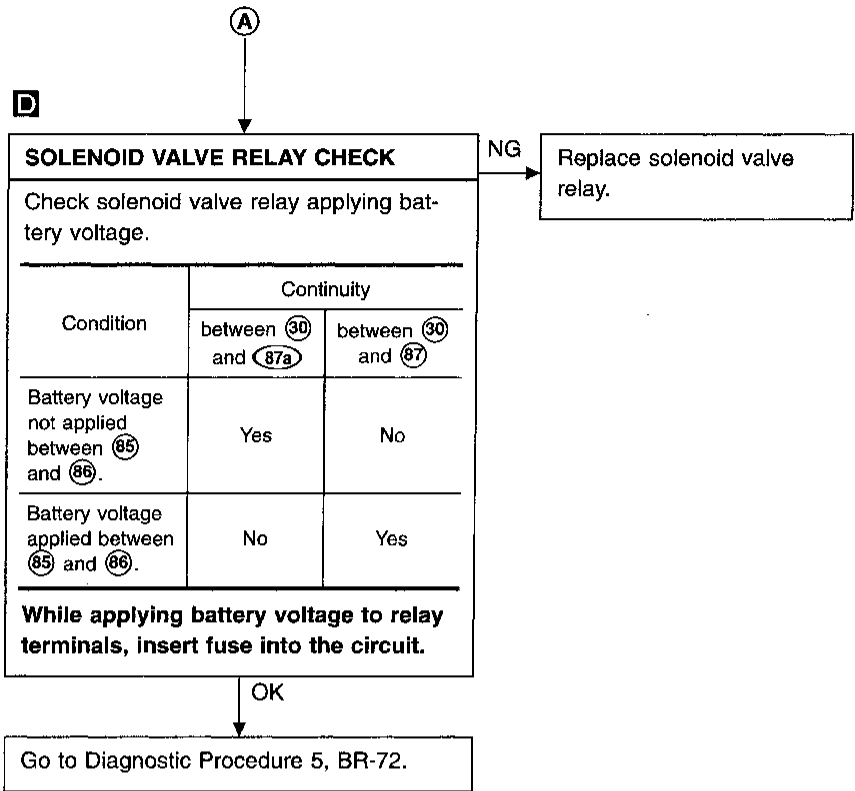
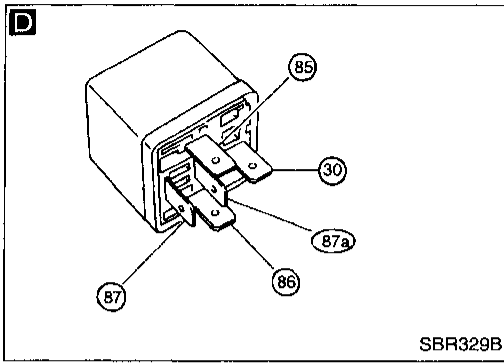

# TROUBLE DIAGNOSES FOR SYMPTOM

## Diagnostic Procedure 8 (Warning Lamp Stays On)

Warning light stays on when ignition switch is turned ON.

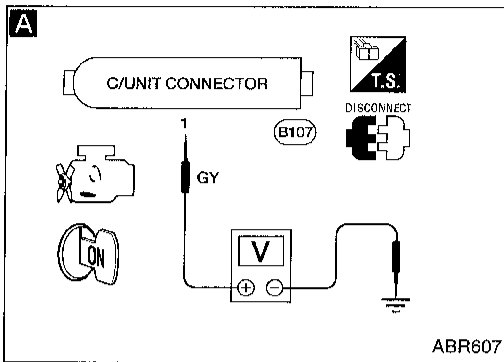

**CONTROL UNIT POWER SUPPLY CIRCUIT**

Check 7.5A fuse 28 for control unit.  
For fuse layout, refer to BR-51.

NG → (Go to ② on BR-77.)

**A**

1. Disconnect connector from control unit.
2. Check voltage between control unit connector terminal ① and ground after turning ignition switch ON.  
**Battery voltage should exist.**

NG → Repair harness and connector.

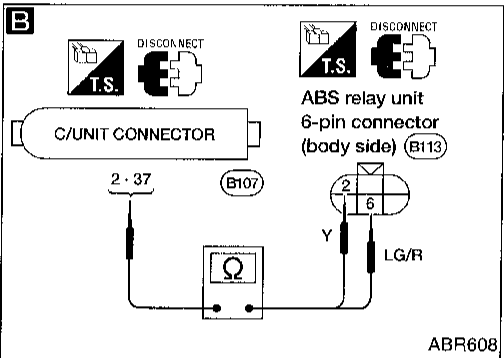

**B**

1. Turn ignition switch OFF. Disconnect ABS relay unit 6-pin connector.
2. Check continuity between control unit connector terminals and ABS relay unit 6-pin connector (body side) terminals.

NG → Repair harness and connector.

Control unit	ABS relay unit
②	②
③7	⑥

**Continuity should exist.**

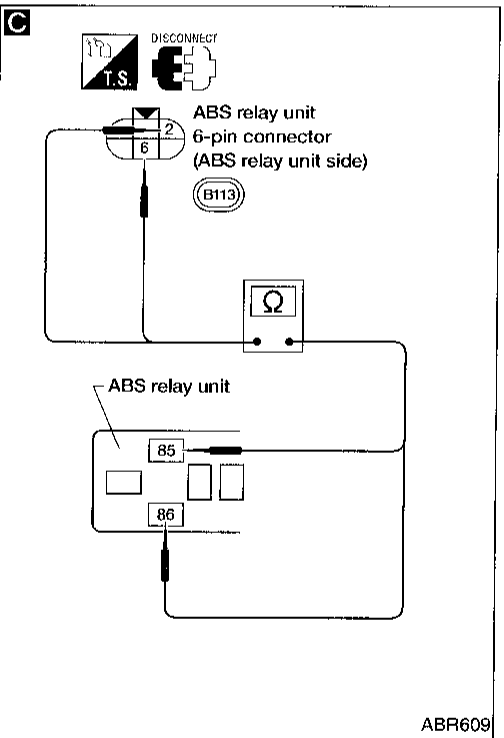

**C**

**CIRCUIT CHECK**

1. Disconnect solenoid valve relay.
2. Check continuity between ABS relay box 6-pin connector (ABS relay unit side) terminals and solenoid valve relay unit terminals.

ABS relay unit connector	ABS relay unit terminals
②	⑧⑥
⑥	⑧⑤

**Continuity should exist.**

NG → Replace ABS relay unit.

OK  
 ↓  
 ①  
 (Go to next page.)

GI

MA

EM

LC

EC

FE

CL

MT

AT

FA

RA

**BR**

ST

RS

BT

HA

EL

IDX

# TROUBLE DIAGNOSES FOR SYMPTOM

## Diagnostic Procedure 8 (Warning Lamp Stays On) (Cont'd)

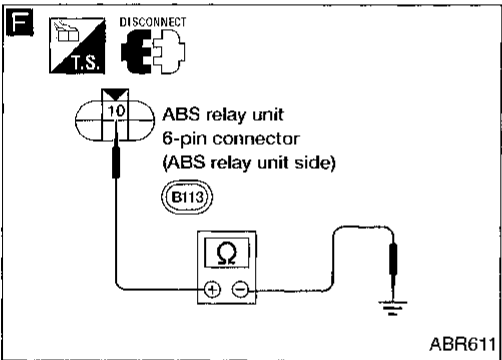
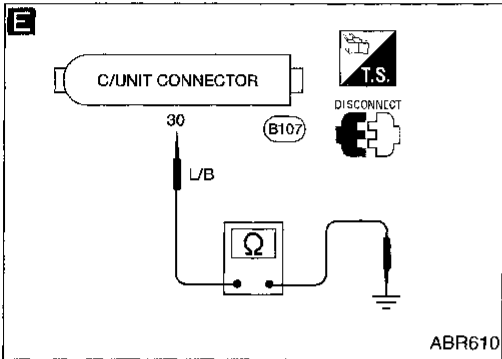
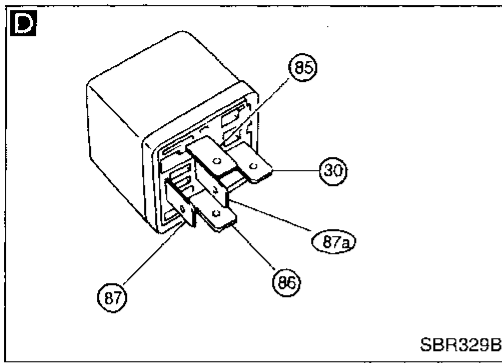

**D**

**SOLENOID VALVE RELAY CHECK**

Check solenoid valve relay applying battery voltage.

Condition	Continuity	
	between (30) and (87a)	between (30) and (87)
Battery voltage not applied between (85) and (86).	Yes	No
Battery voltage applied between (85) and (86).	No	Yes

While applying battery voltage to relay terminals, insert fuse into the circuit.

NG → Replace solenoid valve relay.

**E**

**GROUND-SHORT CHECK FOR WARNING LAMP CIRCUIT.**

1. Turn ignition switch OFF.
2. Disconnect connectors from control unit and ABS relay unit 6-pin connector.
3. Check continuity between control unit connector terminal (30) and body ground.

Continuity should not exist.

NG → Repair harness and connector.

**F**

1. Disconnect actuator ground terminal and ABS relay unit 6-pin connector.
2. Check continuity between ABS relay unit 6-pin connector (ABS relay unit side) terminal (10) and body ground.

Continuity should not exist.

**Note:** Specifications may vary depending on tester type. Before performing this inspection, be sure to refer to the instruction manual for tester being used.

NG → Replace ABS relay unit.

OK → (A)  
(Go to next page.)

# TROUBLE DIAGNOSES FOR SYMPTOM

## Diagnostic Procedure 8 (Warning Lamp Stays On) (Cont'd)

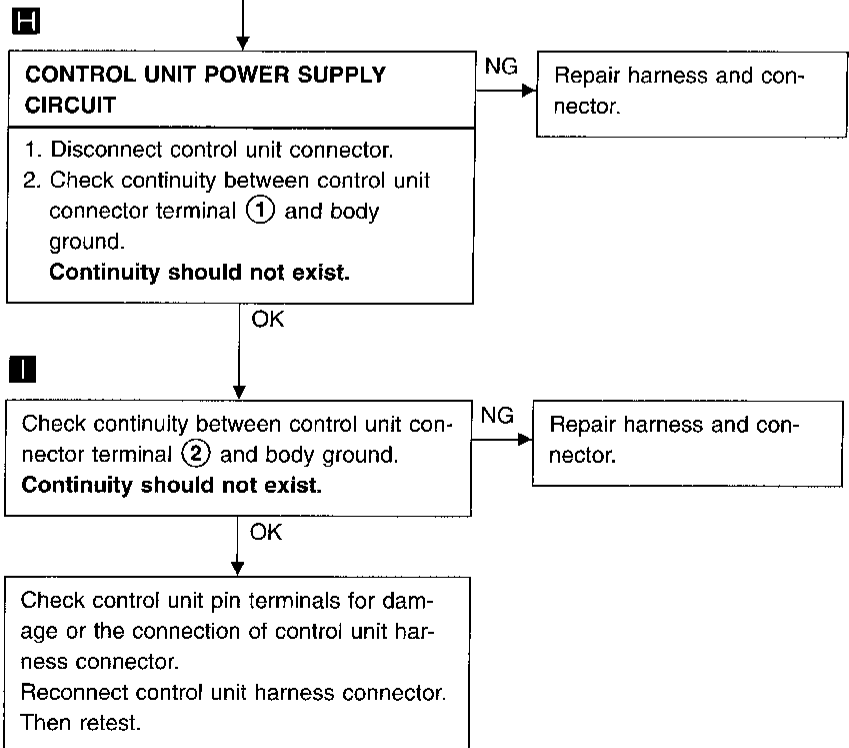
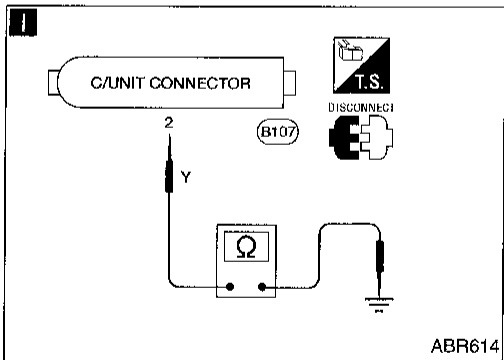
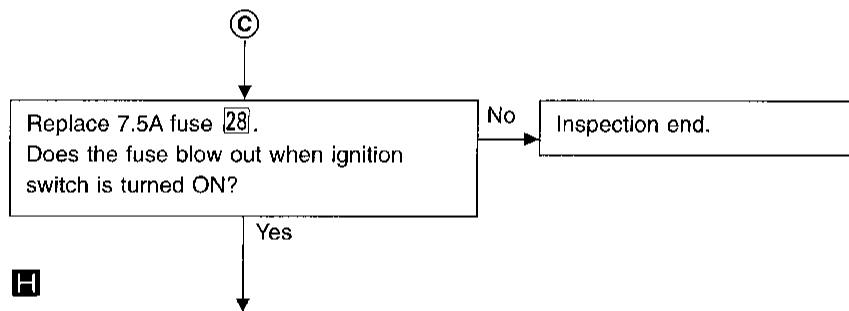
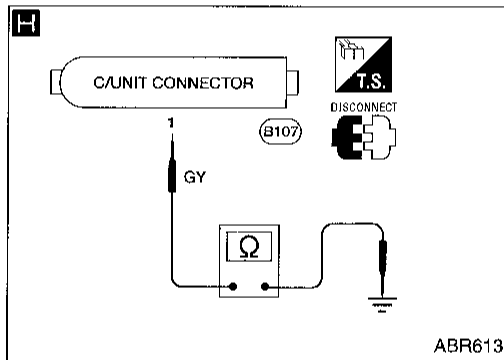
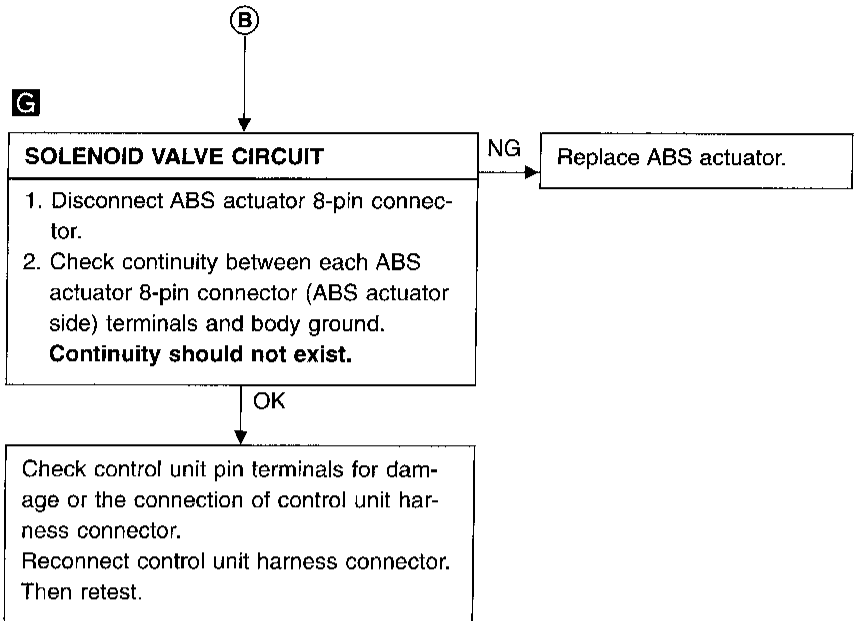
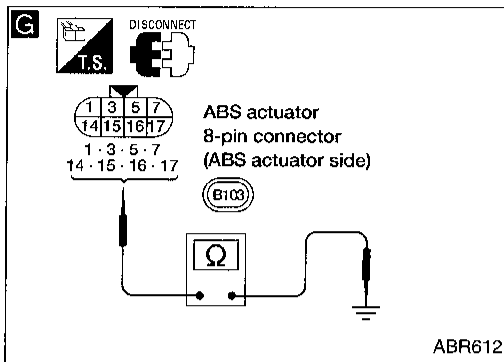

GI  
MA  
EM  
LC  
EC  
FE  
CL  
MT  
AT  
FA  
RA  
BR  
ST  
RS  
BT  
HA  
EL  
IDX

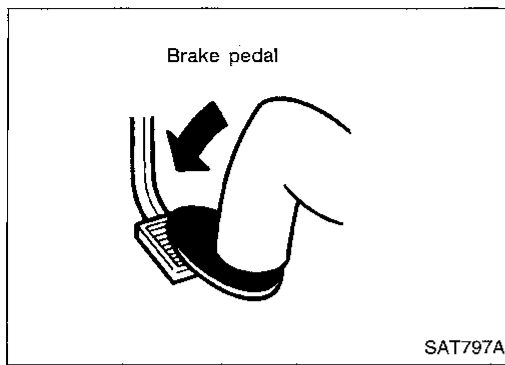

## Diagnostic Procedure 9 (Pedal Vibration and Noise)

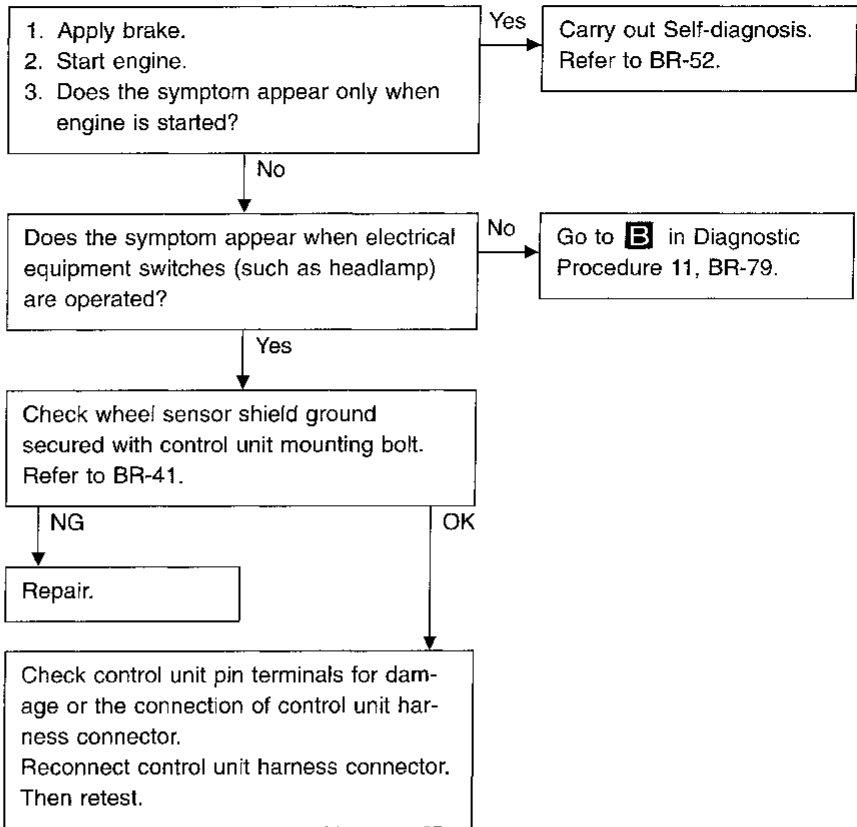

**Note:** ABS may operate and cause vibration under any of the following conditions.

- Applying brake gradually when shifting or operating clutch.
- Low friction (slippery) road.
- High speed cornering.
- Driving over bumps and pot holes.
- Engine speed is over 5,000 rpm with vehicle stopped.

## Diagnostic Procedure 10 (Long Stopping Distance)

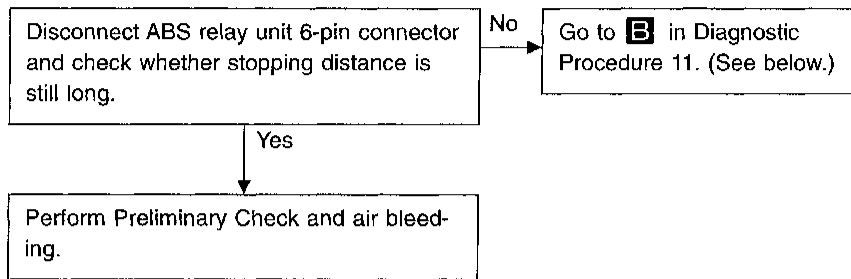

**Note:** Stopping distance may be larger than vehicles without ABS when road condition is slippery.

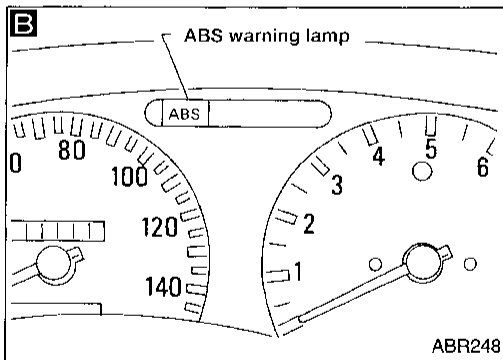
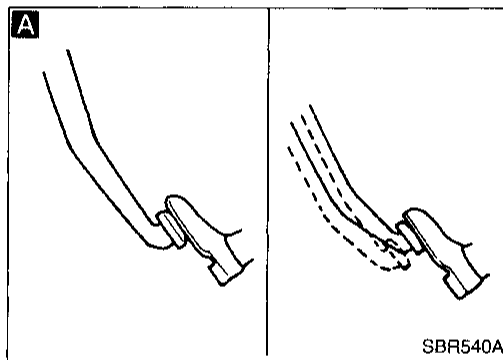

## Diagnostic Procedure 11 (Unexpected pedal action)

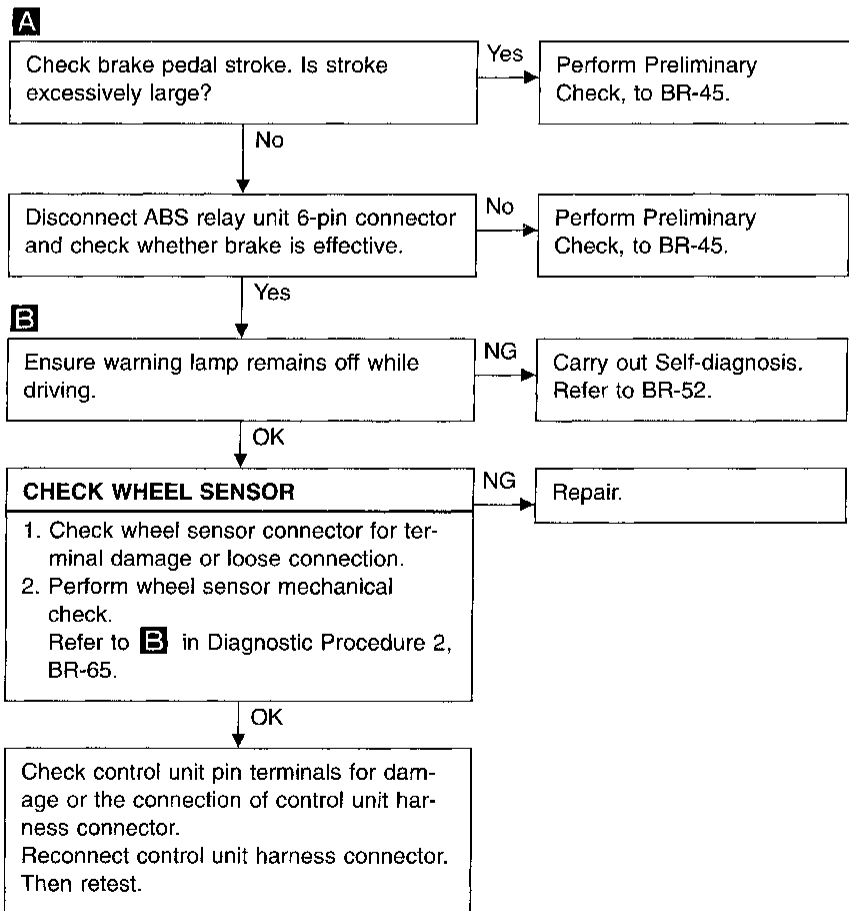

GI  
MA  
EM  
LC  
EC  
FE  
CL  
MT  
AT  
FA  
RA  
**BR**  
ST  
RS  
BT  
HA  
EL  
IDX

## Diagnostic Procedure 12 (ABS Does Not Work)

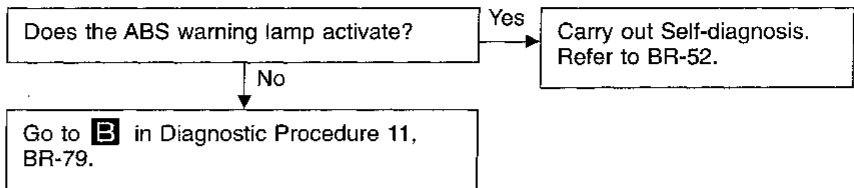

**Note: ABS does not work when vehicle speed is under 10 km/h (6 MPH).**

## Diagnostic Procedure 13 (ABS Works Frequently)

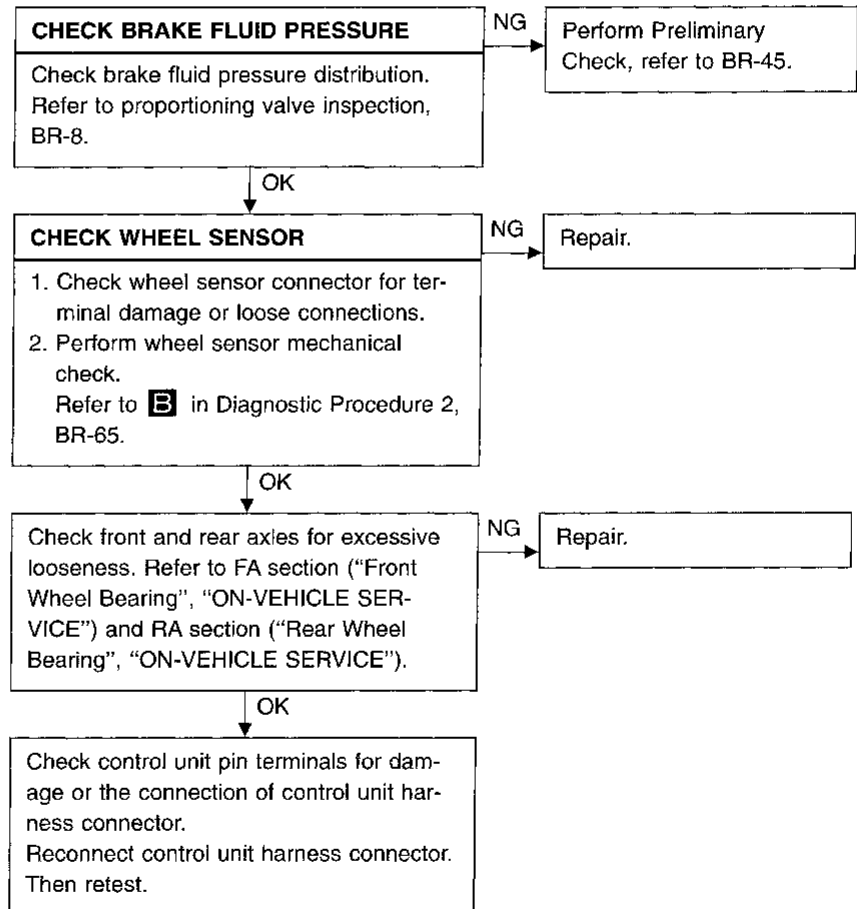



# SERVICE DATA AND SPECIFICATIONS (SDS)

## General Specifications

### BRAKE UNIT

Applied model	Without ABS				With ABS
	4 door Base, XE		4 door GXE, GLE 2 door Base, SE		4 door GXE, GLE 2 door SE
	Standard		Standard		Option
	M/T	A/T	M/T	A/T	—
Front brake	CL22VD		CL22VE		
Brake model					
Cylinder bore diameter mm (in)	54.0 (2.126)				
Pad length x width x thickness mm (in)	106 x 39.5 x 11.0 (4.17 x 1.555 x 0.433)				
Rotor outer diameter x thickness mm (in)	232 x 18 (9.13 x 0.71)		247 x 18 (9.72 x 0.71)		247 x 18 (9.72 x 0.71)
Rear brake	LT18C				CL7HB
Brake model					
Cylinder bore diameter mm (in)	15.87 (5/8)				30.23 (1-1/4)
Lining or pad length x width x thickness mm (in)	172.8 x 30 x 4 (6.80 x 1.18 x 0.16)				94 x 29 x 10 (3.70 x 1.14 x 0.39)
Drum inner diameter or rotor outer diameter x thickness mm (in)	180 (7.09)				234 x 7 (9.21 x 0.28)
Master cylinder	20.64 (13/16)				22.22 (7/8)
Cylinder bore diameter mm (in)					
Control valve	Dual proportioning valve built into master cylinder				Dual proportioning valve separated from master cylinder
Valve model					
Split point [kPa (kg/cm <sup>2</sup> , psi)] x reducing ratio	3,923 (40, 569) x 0.4				3,923 (40, 569) x 0.4
Brake booster	S205 or C205	M195T	S205 or C205	M195T	
Booster model					
Diaphragm diameter mm (in)	205 (8.07)	Primary: 205 (8.07) Secondary: 180 (7.09)	205 (8.07)	Primary: 205 (8.07) Secondary: 180 (7.09)	
Recommended brake fluid	DOT 3				

GI

MA

EM

LC

EC

FE

CL

MT

AT

FA

RA

BR

ST

RS

BT

HA

EL

IDX

# SERVICE DATA AND SPECIFICATIONS (SDS)

## Inspection and Adjustment

### DISC BRAKE

Brake model	Unit: mm (in)	
	Front	Rear
	CL22VD, CL22VE	CL7HB
Standard pad thickness	11 (0.44)	10 (0.39)
Pad wear limit		
Minimum thickness	2.0 (0.079)	1.5 (0.059)
Rotor repair limit		
Minimum thickness	16.0 (0.630)	6.0 (0.236)
Maximum runout	0.07 (0.0028)	
Maximum thickness variation	0.02 (0.0008)	

### DRUM BRAKE

Brake model	Unit: mm (in)	
	Rear	
	LT18C	
Standard lining thickness	4.0 (0.16)	
Lining wear limit		
Minimum thickness	1.5 (0.059)	
Drum repair limit		
Maximum inner diameter	181 (7.13)	
Out-of-round	0.03 (0.0012) or less	

### BRAKE PEDAL

Unit: mm (in)	
Free height "H"	
M/T	148 - 158 (5.83 - 6.22)
A/T	157 - 167 (6.18 - 6.57)
Depressed height	
[under force of 490 N (50 kg, 110 lb) with engine running]	See below.
Clearance between switches and pedal stopper bracket	0.3 - 1.0 (0.012 - 0.039)
Pedal free play (at pedal pad)	1.0 - 3.0 (0.039 - 0.118)

\*: Measured from surface of floor panel.

### Depressed height [Under force of 490 N (50 kg, 110 lb) with engine running]

Unit: mm (in)	
M/T	75 (2.95) or more
A/T	85 (3.35) or more

### PARKING BRAKE CONTROL

Brake type	Drum	Disc
Control type	Center lever	
Number of notches		
[under force of 196 N (20 kg, 44 lb)]	7 - 8	8 - 9
Number of notches when warning lamp comes on	1 or less	